



WE THINK GREEN!



TECHWEST_{INC}

2026 RETAIL CATALOG

TERMS AND CONDITIONS

Prices are subject to change without notice.

No returns are approved without first acquiring a return authorization (RMA) number. All returns are subject to a 15% restock charge. No returns are authorized after 60 days from the date of shipment.

Payment terms are cash with order or a net payment of 30 days on approved credit. A finance charge of 1 1/2% per month will be charged to an account over 30 days.

A credit line must be established on all open accounts.

Any customer who has allowed their account to become delinquent shall pay Tech West for all legal costs incurred during the necessary collection process.

Any customer allowing their account to become delinquent for extended periods beyond our normal terms will lose their privilege of selling the Tech West product line.

WARRANTY

Warranty service must be obtained through a Tech West, Inc. authorized dealer who carries the Tech West, Inc. product line for which warranty service is requested. It is the retail purchaser's obligation to arrange for delivery, at the retail purchaser's expense, of a product through its authorized dealers for warranty service. It is also the retail purchaser's obligation to comply with the warranty service instructions provided either by Tech West, Inc. or its authorized dealer.

Tech West warrants the original retail purchase within the warranty period of such specified product at Tech West, Inc.'s option to repair or replace components of dental products manufactured by Tech West, Inc. that are defective in material or workmanship under normal use and service. Tech West, Inc.'s obligation under this limited warranty is limited to the repair or replacement of the applicable components.

All part and component returns and replacement equipment under warranty require a Return Materials Authorization (RMA). Warranty returns must be received within 15 days of the RMA issue date. Items returned without an RMA, or included with other products for which an RMA has been issued, will be returned to the customer and no credit will be warranted.

Tech West, Inc. is not liable for indirect or consequential damages or loss of any nature in connection with this equipment. Warranty does not cover dealer labor, or shipping and handling charges inbound to Tech West, Inc. Warranty credit will not be applied to product returns that exhibit damage due to shipping, misuse, careless handling, or repairs by Dealer or unauthorized personnel. Credit, or partial credit, will not be issued until products/parts have been received and assessed. Any product is installed or serviced by anyone other than an authorized dealer or service personnel will void all possible warranties.

ALL PARTS HAVE A 90-DAY WARRANTY UNLESS OTHERWISE SPECIFIED.

WARRANTY FOR ALL EXPORT PRODUCT

All Tech West, Inc. products, i.e., vacuums, vacuum systems, and air compressors have a twelve-month or one-year manufacturer's warranty from the date of installation. Our warranty covers only defective parts covered under the warranty period. Labor or other services are excluded.

Warranty does not cover any misuse or improper installation of products. All installation(s) should be installed according to manufacturer installation guidelines. All warranties are evaluated before approval. Improper installations will void all warranties.

All warranty claims export end-users must contact their export distributors.

The terms, conditions, and warranties contained herein supersede all previous terms, conditions, and warranties, written, expressed, or implied, and are in effect January 1, 2024.



TECHWEST^{INC}

Table of Contents

Vacuum Pump Legend	pg. 2
EcoVac Systems	pg. 3
GoldenVac Systems	pg. 4
Evacuation System Cleaners	pg. 5
Air Compressor Legend	pg. 6
Elite Series Oilless Compressors	pg. 7
The Elite Series Oilless Rocky Compressors	pg. 8
Control Panels	pg. 9
Equipment & Accessories	pg. 10-12
Parts List	pg. 13-22

Remittance Address: 2657 N. Argyle Ave. • Fresno, CA 93727
Shipping Address: 2625 N. Argyle Ave. • Fresno, CA 93727
(559) 291-1650 • (800) 428-7139 • FAX (559) 348-9677
www.tech-west.com

MODEL NUMBER LEGENDS FOR VACUUM PUMPS

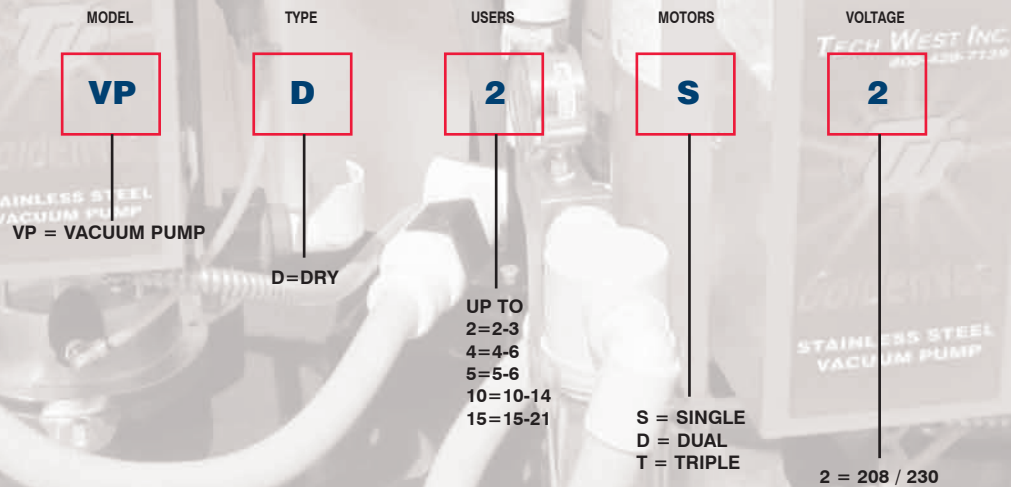
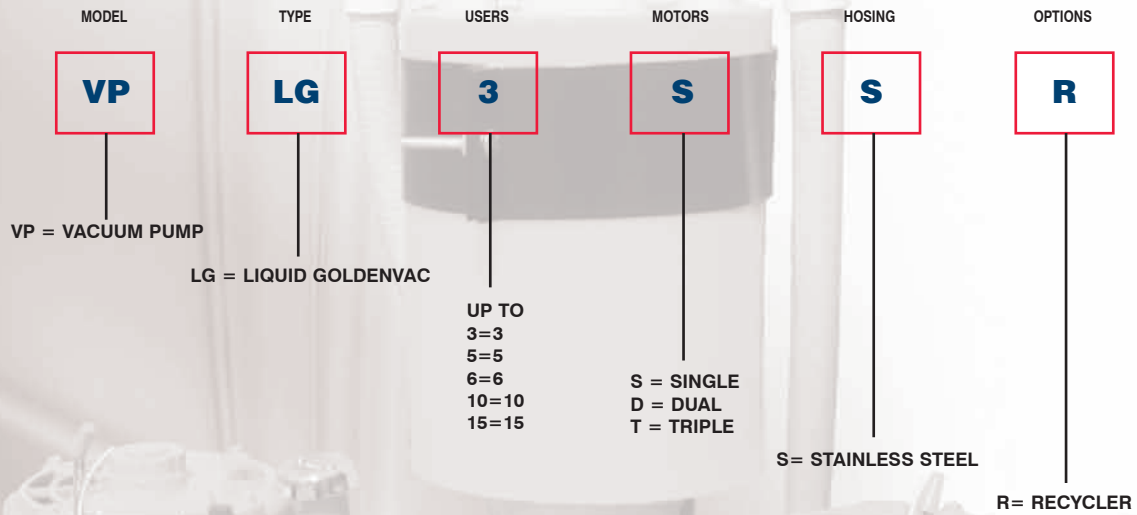

TECH WEST ECOVAC VACUUM PUMP

Our EcoVac system provides the advantages of proven technology, durable construction, quiet operation, and oil-free performance with the latest in water and energy-saving features. This is not only important to you as an environmentally responsible business owner, but it also prepares your practice for the upcoming change to metered water usage in many areas of the country. We utilize a Variable Frequency Drive (VFD) to control the vacuum levels. With no suction being used, the motor is running one-third the speed and using very little power. Every time a suction hose is being used the motor automatically speeds up to maintain constant suction.



Maintenance-free unit with no traps to clean, no oil to check or change. Truly a ZERO maintenance machine.

ECOVAC SYSTEMS

MODEL NUMBER	MAX USERS	# OF HEADS	TOTAL H.P.	CFM @ 8 HG	TANK GALLONS	VOLTAGE	TOTAL AMPS	BREAKER SIZE	DB(A)	EQUIP. WEIGHT	EQUIP. HEIGHT	EQUIP. WIDTH	EQUIP. DEPTH	SHIPPING WEIGHT	SHIPPING HEIGHT	SHIPPING WIDTH	SHIPPING DEPTH	LIST PRICE
VPD2S2	2-3	1	2	20	14	208/230	5	20	60	139	52	23	20	220	44	42	31	15,025
VPD2S2-NT	2-3	1	2	20	N/A	208/230	5	20	60	139	52	23	20	220	44	42	31	14,067
VPD5S2	5-7	1	2	45	14	208/230	7	20	62	139	52	23	20	220	44	42	31	16,753
VPD5S2-NT	5-7	1	2	45	N/A	208/230	7	20	62	139	52	23	20	220	44	42	31	16,005
VPD4D2	4-6	2	4	40	14	208/230	10	2X20	62	282	39	40	20	350	44	42	31	27,479
VPD10D2	10-14	2	4	90	30	208/230	14	2X20	62	282	39	40	20	325	44	43	31	31,410
VPD10D2-14	10-14	2	4	90	14	208/230	14	2X20	62	350	39	43	31	350	45	31	43	31,410
VPD10D2-NT	10-14	2	4	90	N/A	208/230	14	2X20	62	350	45	43	31	350	45	31	43	28,887
VPD15T2	15-21	3	6	110	40	208/230	21	3X20	62	402	60	40	20	455	44	42	31	47,691

DVU-S Upgrade 2-3 user single to 5-7 user: 2,949

DVU-D Upgrade 4-6 user dual to 10-14 user: 5,900

(VPD10D2 has a 30 gallon tank. Tank weight: 157 lbs. Tank dimensions: 27"W x 28"D x 61"H)

5 YEAR WARRANTY OR 5000HRS ON MOTOR, 2 YEARS WARRANTY ON ALL OTHER COMPONENTS

FDA
RECOGNIZED

Meets or exceeds NFPA applicable guidelines

www.tech-west.com

TECH WEST

GOLDENVAC STAINLESS STEEL VACUUM PUMP



The Tech West GoldenVac has proved to be the industry leader in design and performance. A vacuum system you can rely on for years to come. All GoldenVac vacuum pumps have an exclusive warranty with 10 years on all stainless steel pump parts, 5 years on the motor shaft and all other components come with a 3 year warranty. GoldenVac vacuum pumps have an investment cast stainless steel impeller with a radical new design that improves performance by 20% over other pumps. The stainless steel castings provide maximum durability to prevent wear from air abrasion and ceramic particles, or hard water conditions. All motors are thermally protected and are cap-start, and cap-run. This will lower the electrical consumption of the pump. Water recyclers and air-water separators are available for all pumps. The GoldenVacs are available in single, dual, or triple configurations. Tech West will provide plumbing and electrical designs upon request.

GOLDENVAC SYSTEMS

MODEL NUMBER	# OF USERS	VOLTAGE	BREAKER SIZE	H.P.	AIR/WATER SEP	DB(A)	EQUIP. HEIGHT	EQUIP. DEPTH	EQUIP. WIDTH	EQUIP. WEIGHT	SHIPPING HEIGHT	SHIPPING DEPTH	SHIPPING WIDTH	LIST PRICE	
VPLG3SS	3	115/230	20	1	NO	70	18	13	13	73	22	18	18	85	4,668
VPLG3SSR	3	115/230	20	1	NO	70	18	13	13	75	22	18	18	87	4,846
VPLG5SS	5	208/230	20	2	NO	70	18	13	13	89	22	18	18	85	5,939
VPLG5SSR	5	208/230	20	2	NO	70	18	13	13	91	22	18	18	87	6,201
VPLG6D2	6	208/230	2X20	2X1	YES	72	30	20	28	197	34	21	37	210	9,800
VPLG6D2R	6	208/230	2X20	2X1	YES	72	30	20	28	200	34	23	37	212	10,139
VPLG10D2	10	208/230	2X20	2X2	YES	72	30	20	28	227	34	23	37	221	11,665
VPLG10D2R	10	208/230	2X20	2X2	YES	72	30	20	28	230	34	23	37	223	12,156
VPLG15T2	15	208/230	3X20	3X2	YES	74	30	20	41	213	34	23	49	298	16,790
VPLG15T2R	15	208/230	3X20	3X2	YES	74	30	20	41	215	34	23	49	300	17,966

WARRANTY: 10 YEARS ON STAINLESS STEEL PARTS, 5 YEARS ON MOTOR SHAFT,
3 YEARS ON ALL OTHER COMPONENTS

FDA
RECOGNIZED

Meets or exceeds NFPA applicable guidelines

TECH WEST EVACUATION SYSTEM CLEANER



Evacuation System Cleaner

The amount of waste residue (Biofilm/plaque) slogging down your evacuation system depends on the age of your facility, water supply pH, chemical cleaner in use, and how much/often it was used. The Restore Protocol will release the Biofilm/plaque material from the inside of your lines/pipes.

Tech West's Microbial Formula digests organic matter and solids which **GUARANTEES TO MAINTAIN SUCTION PERFORMANCE** and "ELIMINATE" Daily Trap Hand Cleaning. 100% All Natural & Biodegradable. Non-Foaming & SAFE for humans, animals, plants, and pipes.

EcoStar-eVac Cleaner comes in two different sizes and the initial amount used to restore the system depends on the age of the system. Detailed instructions are available upon request. It is recommended that EcoStar-eVac Cleaner be used to maintain your system once it is initially cleaned. This will insure cleanliness and long life of the system.

PART#	DESCRIPTION		LIST PRICE
ESC-16	EcoStar-eVac Cleaner	16 oz.	80
ESC-32	EcoStar-eVac Cleaner	32 oz.	140
ESC-KIT	EcoStar HVE & Si Dispenser	16 oz.	133

Note: It is recommended to use 4 oz / chair per month

MODEL NUMBER LEGENDS FOR AIR COMPRESSORS

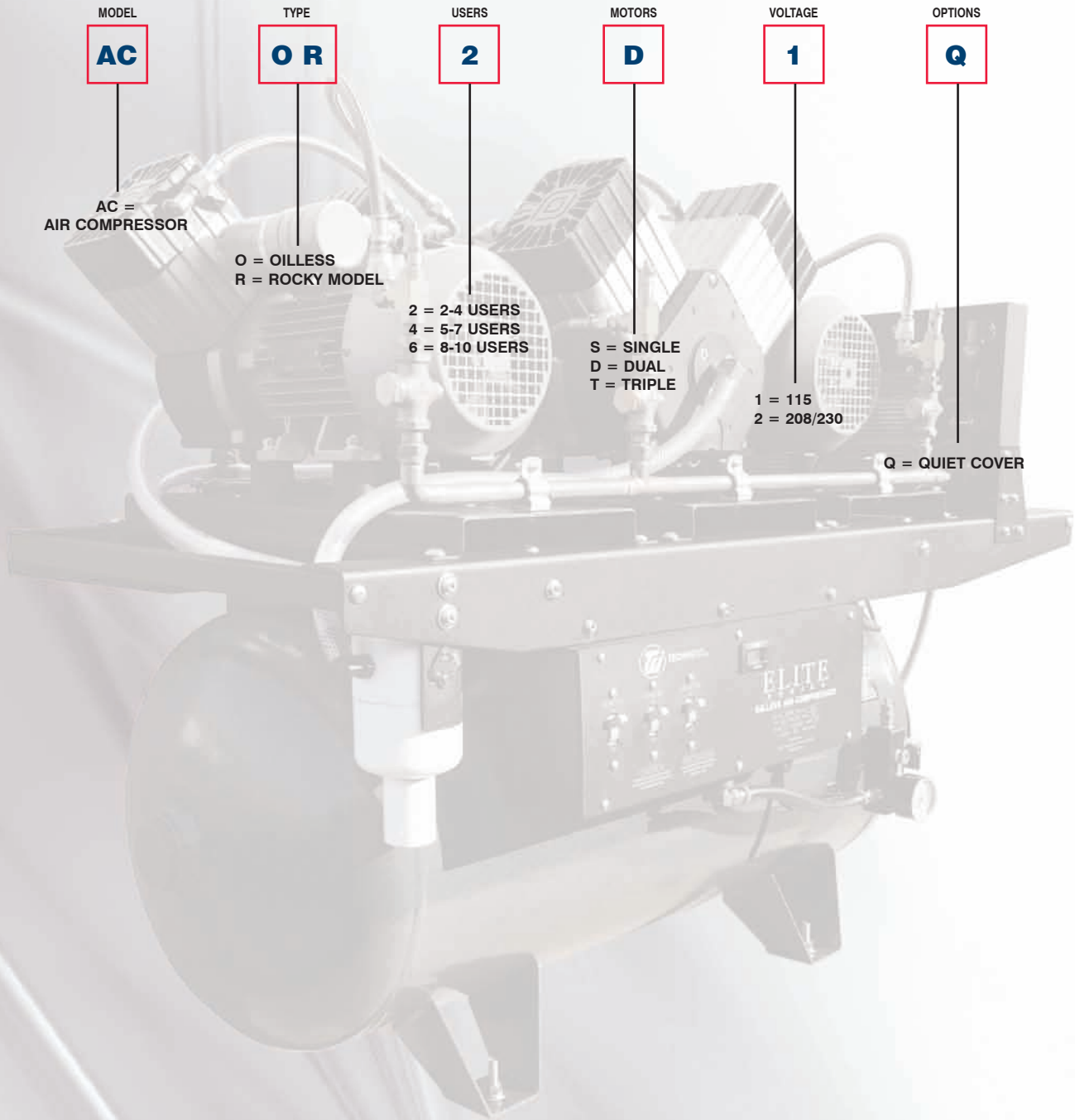

MODEL

AC

AC =
AIR COMPRESSOR

TYPE

OR

O = OILLESS
R = ROCKY MODEL

USERS

2

2 = 2-4 USERS
4 = 5-7 USERS
6 = 8-10 USERS

MOTORS

D

S = SINGLE
D = DUAL
T = TRIPLE

VOLTAGE

1

1 = 115
2 = 208/230

OPTIONS

Q

Q = QUIET COVER

TECH WEST

ELITE SERIES ULTRA CLEAN OILLESS COMPRESSOR

Our Elite Series Oilless Air Compressor system provides the advantages of proven technology, durable construction, quiet operation, and oil-free performance with the latest in energy-saving features. This is important to you as an environmentally responsible business owner.

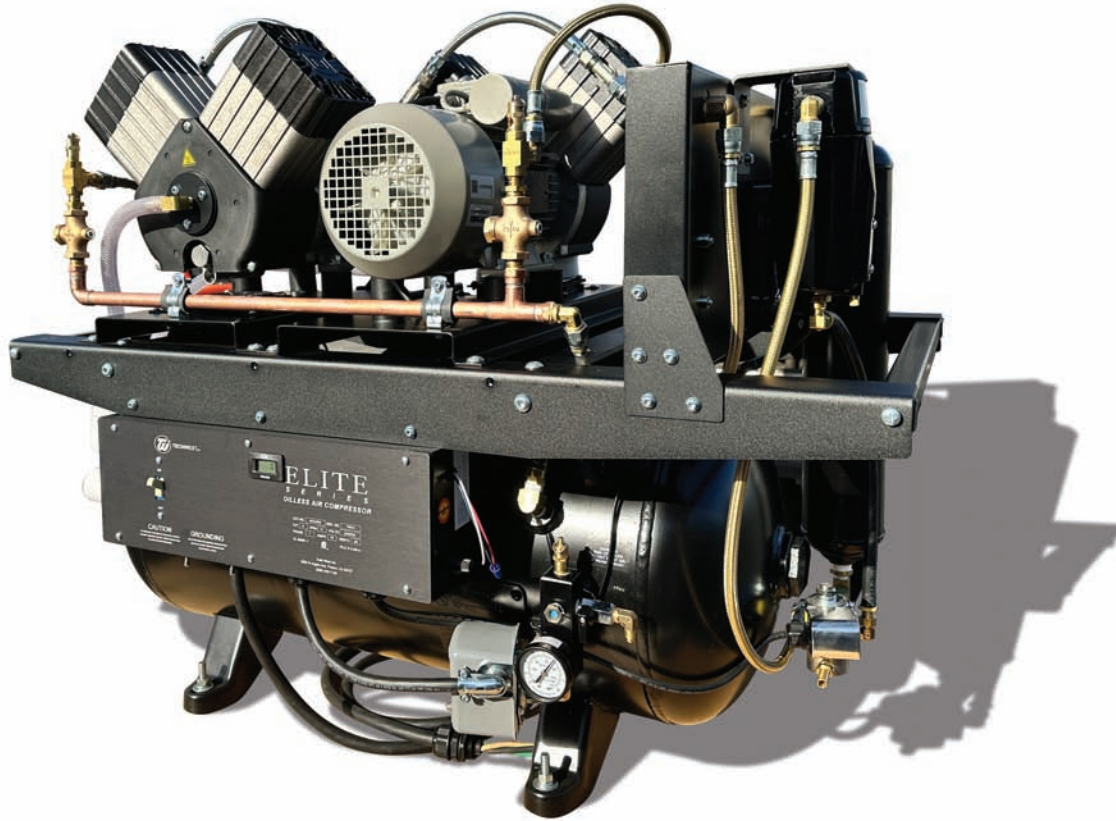

OILLESS AIR COMPRESSORS

MODEL NUMBER	MAX USERS	AIR DRYER	QUIET COVER	# OF HEADS	TOTAL H.P.	CFM	TANK GALLONS	VOLTAGE	TOTAL AMPS	BREAKER SIZE	DB(A)	EQUIP. WEIGHT	EQUIP. HEIGHT	EQUIP. WIDTH	EQUIP. DEPTH	SHIPPING WEIGHT	SHIPPING HEIGHT	SHIPPING WIDTH	SHIPPING DEPTH	LIST PRICE
ACO2S2	2-3	YES	NO	1	1.5	5.5	10	208/230	8	20	70	180	30	28	20.5	220	37	34	28	9,775
ESCRD-100	OPTIONAL QUIET COVER FOR THE ACO2S2										68	50	15	19	19	50	19	33	19	2,124
ACO4D2	5-7	YES	NO	2	3	11	20	208/230	16	30	72	248	34	38	22	335	44	42	30	14,970
ACO6T2	8-10	YES	NO	3	4.5	16.5	30	208/230	25.5	40	74	320	36	46	25	368	45	48	33	20,675
ESCD-100	QUIET COVER: OPTIONAL FOR THE ACO4D2										68	50	17	29	22	50	21	27	23	2,788

A 5 YEAR OR 3500 HR MOTOR WARRANTY. ALL OTHER COMPONENTS CARRY A 2 YEAR WARRANTY

Meets or exceeds NFPA applicable guidelines

FDA
RECOGNIZED

TECH WEST

ELITE SERIES ROCKY OILLESS AIR COMPRESSOR

The Tech West Rocky Series Oilless Air Compressors provide 100% oil-free air to the dental office. With our high-performance air drying system, we guarantee the clean dry air you expect. The design of the Tech West Rocky Series Air Compressor provides smooth, quiet, vibration-free operation at only 65 dB-a noise level. We offer them in a twin configuration to meet almost any need of today's Dental Practice. Tech West will provide full plumbing and electrical design upon request.

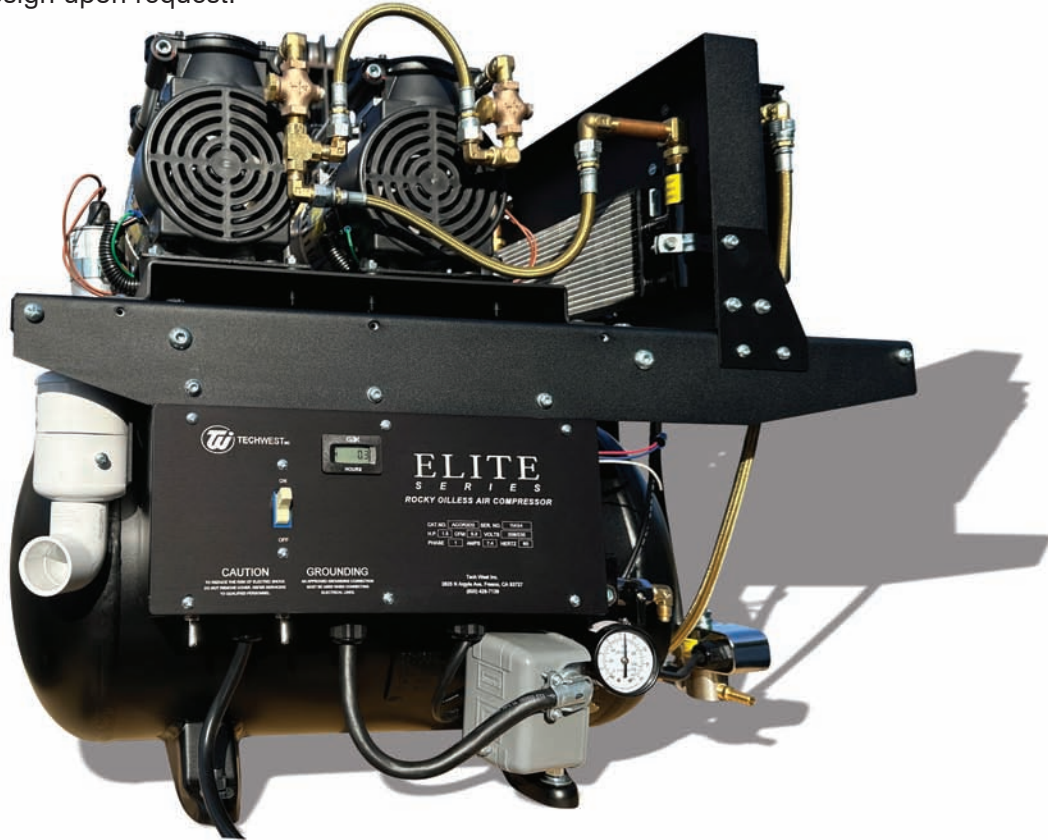

ROCKY OILLESS AIR COMPRESSORS

MODEL NUMBER	MAX USERS	AIR DRYER	QUIET COVER	# OF HEADS	TOTAL H.P.	CFM	TANK GALLONS	VOLTAGE	TOTAL AMPS	BREAKER SIZE	DB(A)	EQUIP. WEIGHT	EQUIP. HEIGHT	EQUIP. WIDTH	EQUIP. DEPTH	SHIPPING WEIGHT	SHIPPING HEIGHT	SHIPPING WIDTH	SHIPPING DEPTH	LIST PRICE
ACOR2D1	2-3	YES	NO	2	1.5	5.2	10	115	11	20	68	175	28	28	20.5	220	37	34	28	9,955
ACOR2D1Q	2-3	YES	YES	2	1.5	5.2	10	115	11	20	64	210	31	28	20.5	220	37	34	28	11,202
ACOR2D2	2-3	YES	NO	2	1.5	5.2	10	208/230	8	20	68	175	28	28	20.5	220	37	34	28	9,955
ACOR2D2Q	2-3	YES	YES	2	1.5	5.2	10	208/230	8	20	64	210	31	28	20.5	220	37	34	28	11,202

A 5 YEAR 3500 HOUR MOTOR WARRANTY. ALL OTHER COMPONENTS CARRY A 2 YEAR WARRANTY.

Meets or exceeds NFPA applicable guidelines

FDA
RECOGNIZED

TECH WEST

REMOTE CONTROL PANELS

Tech West's Remote Control Panels offer a wide variety of different models to suit almost any need. All the panels are brushed aluminum with a clear anodized coating that can be mounted onto standard electrical junction boxes.



PART #	DESCRIPTION	HEIGHT	WIDTH	RETAIL PRICE
CP-1V	CONTROL PANEL 1 VAC	4 1/2	4 1/2	293
CP-1V1A	CONTROL PANEL 1 VAC 1 AIR	4 1/2	4 1/2	551
CP-1V1A1W	CONTROL PANEL 1 VAC 1 AIR 1 H2O	4 1/2	6 1/2	697
CP-2A1W	CONTROL PANEL 2 AIR 1 H2O	4 1/2	6 1/2	736
CP-2V	CONTROL PANEL 2 VAC	4 1/2	4 1/2	551
CP-2V1A	CONTROL PANEL 2 VAC 1 AIR	4 1/2	6 1/2	736
CP-2V1A1W	CONTROL PANEL 2 VAC 1 AIR 1 H2O	4 1/2	6 1/2	845
CP-3V	CONTROL PANEL 3 VAC	4 1/2	6 1/2	736
CP-3V1A	CONTROL PANEL 3 VAC 1 AIR	4 1/2	6 1/2	736
CP-3V1A1W	CONTROL PANEL 3 VAC 1 AIR 1 H2O	4 1/2	6 1/2	919
CP-4V	CONTROL PANEL 4 VAC	4 1/2	6 1/2	736
CPB-100	CONTROL PANEL BULB (3PK)	N/A	N/A	61

CONTROL PANELS CARRY A 2 YEAR WARRANTY

TECH WEST WATER MANIFOLDS

Tech West's Water Manifolds offer safe after-hours protection for today's dental offices. Just push a button on the remote control panel and the water is off. Manifolds are available with or without a filter and with or without a low voltage contactor. The 3/4" unit has a clear filter housing and the 1" has a blue housing.



PART #	DESCRIPTION	HEIGHT	WIDTH	DEPTH	WEIGHT	RETAIL PRICE
WB-100	WTR BYPASS 1" NO FILTER	13	19	4	16	2,227
WB-100-RC	WTR BYPASS 1" NO FILTER W/RELAY	13	19	4	22	2,430
WB-750	WTR BYPASS 3/4" NO FILTER	10	15 1/2	4	13	1,315
WB-750-RC	WTR BYPASS 3/4" NO FILTER W/RELAY	10	15 1/2	4	18	1,618
WBF-100	WTR BYPASS FILTER 1" NO RELAY	24	25	7 1/2	25	2,632
WBF-100-RC	WTR BYPASS FILTER 1" W/RELAY	24	25	7 1/2	31	3,041
WBF-750	WTR BYPASS FILTER 3/4" NO RELAY	21	19 1/2	6	15	1,721
WBF-750-RC	WTR BYPASS FILTER 3/4" W/RELAY	21	19 1/2	6	18	2,025

PART #	DESCRIPTION	WEIGHT	RETAIL PRICE
WFE-750	3/4" FILTER ELEMENT PKG OF 4	3	182
WFE-100	1" FILTER ELEMENT PKG OF 4	8	365

TECH WEST WATER MANIFOLDS HAVE A FULL 2 YEAR WARRANTY

TECH WEST PUMP ACCESSORIES



WATER RECYCLER

Tech West's water recycler is a simple yet effective way to save as much as 70% of water consumption. It is factory installed on the pump or can be field installed with ease.

PART#	DESCRIPTION	PRICE
WRK-100	WATER RECYCLER KIT	459

P-TRAP ADAPTER

The P-Trap adapter is designed to be used with all Whirlwind/Goldenvac Pump models with exhaust separators. The separator waste connection may be hooked to the P-Trap Adapter without worry of splash or vapor contamination. It includes a 1 1/2" ABS slip connection to P-Trap, a stainless steel bridge assembly with 90 degree PVC elbow and adapters for 3/4 drain flex lines.



PART#	PRICE
PTA-100	179

STACKING RACK

The stacking rack is designed to reduce the space required to install vacuum and air equipment by about half. The space savings is achieved by placing the stacking rack over your compressor and installing your platform mounted Whirlwind/Goldenvac pumps on the rack. The stacking rack fits both the dual and triple vacuum systems.



PART #	HEIGHT	WIDTH	DEPTH	WEIGHT	RETAIL PRICE
SR-100	39	43	27	75	1,288

AIR WATER SEPARATOR WITH VAPOR STOP

Air-water separators are available in single, dual, and triple models. They are designed to separate the liquids entrained in the exhaust. A vapor-stop fitting allows the liquids to create a gas and vapor trap, thereby eliminating odors and contaminants from entering the equipment location. All models include vapor-stop, hoses, fittings, P-trap adapter and a mounting bracket.



PART #	DESCRIPTION	HEIGHT	WIDTH	DEPTH	WEIGHT	RETAIL PRICE
ES-1	SINGLE	16	16	9	18	767
ES-2	DUAL	16	16	9	18	879
ES-3	TRIPLE	16	16	11	18	991

TECH WEST ACCESSORIES

COMPRESSOR OIL

Our compressor oil is specially formulated for our oil lubricated compressors. It is a very high grade of synthetic lubricant with an additive to help reduce piston friction and wear.



PART# CO-100 PRICE 83
(Case of 4)

RELAY CONTROL 24V/115-230V

For 24V remote switching of compressors, water manifolds, and other electrical devices. Relay provides 40 amp. resistive load capability, 30VA and 24 VAC transformer. Fused on 24V side.

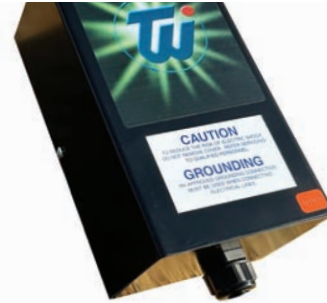

PART#	DESCRIPTION	PRICE
RC-115	115V RELAY CONTROL	416
RC-230	230V RELAY CONTROL	416

BOOST TRANSFORMER

When line voltage at an installation site is below 208 volts for a pump or compressor, it is recommended that a boost transformer be installed. They are pre-wired for quick installation. Select your booster based on the total horsepower of your pump or compressor. All dual and triple-model Whirlwinds should use individual boosters for each vacuum pump or separate circuits.



PART #	DESCRIPTION	WEIGHT	RETAIL PRICE
BT-2-230	2 HP 230 V.	18	1,104
BT-3-230	3 HP 230 V.	23	1,288

BOOST TRANSFORMERS CARRY A 2 YEAR WARRANTY

TECH WEST RETAIL PRICE LIST - PARTS

PART NUMBER	DESCRIPTION	RETAIL PRICE
AS-500	AIR STONE 1/2MPT X 3/8FPT	118
BB-6-4	BRASS BUSHING 3/8 X 1/4	12
BN-125-CL	BRASS NIPPLE 1/8 CLOSE	3
BN-250-1.50	BRASS NIPPLE 1/4 X 1 1/2	22
BN-250-CL	BRASS NIPPLE 1/4 CLOSE	3
BN-6-CL	BRASS NIPPLE 3/8 CLOSE	4
BN-750-2	BRASS NIPPLE 3/4 X 2	29
BN-750-CL	BRASS NIPPLE 3/4 CLOSE	21
BPC-4	BRASS PIPE CROSS 1/4	34
BPP-4	BRASS PIPE PLUG 1/4	3
BRN-4-2	BRASS REDUCER NIPPLE 1/4 X 1/8	9
BSE-2	BRASS STREET ELBOW 1/8	18
BSE-250	BRASS STREET ELBOW 1/4	9
BT-2-230	BOOST TRANSFORMER 2HP	1,104
BT-250	BRASS TEE 1/4	22
BV-250-FM	BALL VALVE 1/4 FEMALE TO MALE	22
CF-115-230E	COOLING FAN DUAL VOLTAGE 115/230VLT	137
CFAO-375	COALESCING FILTER ASSEMBLY 3/8	630
CFAO-375-100	COALESCING FILTER ASSY	581
CFAO-375-100	COALESCING FILTER ASSY	581
CFB-375	COALESCING FILTER BOWL	293
CFB-P	COALESCING FILTER BRACKET	43
CFBP	COALESCING FILTER BOWL PARKER	404
CFE-375	COAL FILTER ELEMENT #18 .01MIC	209
CFEO-375	COAL FILTER ELEMENT PARKER	209
CFG-100	COOLING FAN FINGER GUARD	21
CFSG-100	COALESCING FILTER SIGHT GLASS	123
CO-100	OIL FOR TURBINE COMPRESSOR CS4	83
CO-100	COMPRESOR OIL-CASE OF 4	83
CO-100-1	OIL,CMPRSR,SGL BTL	22

TECH WEST RETAIL PRICE LIST - PARTS

PART NUMBER	DESCRIPTION	RETAIL PRICE
CP-1A	CONTROL PANEL 1AIR	293
CP-1A	CONTROL PANEL 1 AIR	293
CP-1V1W	CONTROL PANEL 1 VACUUM 1 WATER	323
CP-2V1W	CONTROL PANEL W/ 2VAC &	701
CP-4V1A	CONTROL PANEL 4 VAC 1AIR	701
CPB-100	CONTROL PANEL BULB PK3	61
CPB-100	BULBS,CONTROL PANEL,3/PK	61
CPG-250	PRESSURE GAUGE	82
CPG-250	PRESSURE GAUGE	82
CPS-100	CONTROL PANEL SWITCH	173
CPS-100	CONTRL PANL SWTCH-VAC ORAIR	245
CPS-100V	CONTROL PANEL SWITCH	347
CPS-100VS	CONTROL PANEL SWITCH	190
CPSA-100	CONTROL PANEL SWITCH AIR	246
CPSA-100	CNTRL PNL SWITCH,AIR W/LENS,	246
CPSH-100	SWITCH CONTROL PANEL	507
CPSH-100	SWITCH,WATER CONTRL PANEL	507
CPSH1-100	SWITCH CONTROL PANEL H2O	250
CPSLA-100	CONTROL PANEL SWITCH LENS-AIR	56
CPSLB-100	CONTROL SWITCH PANEL LENS BLAN	16
CPSLH-100	CONTROL PANEL SWITCH LENS-H2O	56
CPSLV-100	CONTROL PANEL SWITCH LENS-VACUUM	56
CPSV-100	CONTROL PANEL SWITCH-VACUUM	214
CSK-2	SERVICE KIT DUAL COMPRESSOR	216
CSKL-1	COMP. SERVICE KIT, SINGLE LUB WILKERSON BOWL	268
CSKL-1P	COMP. SERVICE KIT, SINGLE LUB PARKER BOWL	268
CSKL-2	COMP. SERVICE KIT, DUAL LUB WILKERSON BOWL	289
CSKL-2P	COMP. SERVICE KIT, DUAL LUB PARKER BOWL	391
CSKL-3	COMP. SERVICE KIT, TRIPLE LUB WILKERSON BOWL	332
CSKL-3P	COMP. SERVICE KIT, TRIPLE LUB PARKER BOWL	332

TECH WEST RETAIL PRICE LIST - PARTS

PART NUMBER	DESCRIPTION	RETAIL PRICE
CSKO-1	COMP. SERVICE KIT, SINGLE OILLESS WILKERSON BOWL	315
CSKO-1P	COMP. SERVICE KIT, SINGLE OILLESS PARKER BOWL	315
CSKO-2	COMP. SERVICE KIT, DUAL OILLESS WILKERSON BOWL	395
CSKO-2P	COMP. SERVICE KIT, DUAL OILLESS PARKER BOWL	395
CSKO-3	COMP. SERVICE KIT, TRIPLE OILLESS WILKERSON BOWL	501
CSKO-3P	COMP. SERVICE KIT, TRIPLE OILLESS PARKER BOWL	501
CV-250	BRASS CHECK VALVE 1/4 SPRING	114
CV-250D	1/4" CHECK VALVE MNPT X MNPT	62
CV-375	BRASS CHECK VALVE 3/8 SPRING	121
CV-375MF	BRASS CHECK VALVE 3/8 MF	98
CV-375MF-100	CHECK VLV RETRO KIT FOR	80
CVF-1.25	PVC CHECK VALVE 1 1/4-FLO	110
CVF-750	PVC CHECK VALVE 3/4-FLO	81
CVK-750	PVC CHECK VALVE 3/4-KING	98
CVP-15M	CENTRIFUGAL VACUUM PUMP 15HP	42,470
CVP-75M	CONTRIFUGAL VACUUM PUMP 7.5HP	27,573
CVS-1.25	PVC CHECK VALVE 1 1/4"	142
CVS-1.25	PVC CHECK VLV 1 1/4" SPEARS	142
DC-250	BRASS DRAINCOCK 1/4	18
DCV-100	DUAL VAC PUMP CHECK VALVE ASSY	378
DDSK-100	DRYER DESICANT SERVICE KIT	221
DPA-100	DUAL PLATFORM ASSEMBLY	1,442
DPB-100	DRYER PURGE BUCKET 2 GAL W/LID	34
DSV-115	DRYER SOLENOID VALVE 115 VOLT	389
DSV-230	DRYER SOLENOID VALVE 230 VOLT	389
DSVM	MOTOR 3/4 HP SURGICAL VAC	5,031
DVAC-24	DRY VAC AUTO CLOCKS 24 VOLT	713
DVCVA-1.25	DRY VAC CHECK VLV ASSY 1 1/4"	150
DVEH-2	DRY VAC EXHAUST HOSE 2	33
DVHK-1.25-S	DRY VAC HOOK 1-1/4" KT	188

TECH WEST RETAIL PRICE LIST - PARTS

PART NUMBER	DESCRIPTION	RETAIL PRICE
DVR-24DPDT	DRYVAC RELAY	51
DVR-24DPDT	DRY VAC RELAY DUAL POLE	51
DVRC-2X1.25	DRYVAC REDUCER COUPLING 2X1.25	47
DVRC-SPDT	DV RELAY CONTACTOR 1 POLE	47
DVRS-1PDT	SINGLE POLE RELAY SOCKET	35
DVRS-24DPDT	DRY VAC RELAY SOCKET DUAL POLE	66
DVU-D	UPGRADE 4-6 USER DUAL TO 10-14 USER	6,195
DVU-S	UPGRADE 2-3 USER SINGLE TO 5-7 USER	3,096
EC-115	EXTENSION CORD 6FT 115V	28
EC-230	EXTENSION CORD 6FT 230V	32
EDT-100	ELITE DESICCANT TANK W/ DESICCANT BEADS	1,083
EM-100	EXHAUST MUFFLER	85
EM-100	EXHAUST MUFFLER	85
EOM-1.50-230	ELITE OILLESS MOTOR 1.5HP/115V W/MOTOR MOUNT	5,876
EOM-150-230V	ELITE OILLESS MOTOR 1.5 HP/230 V 60HZ	4,822
ES-1	SINGLE SEPERATOR WITH VAPOR STOP	767
ES-2	DUAL SEPERATOR WITH VAPOR STOP	879
ES-3	TRIPLE SEPERATOR WITH VAPOR STOP	991
ESC-16	ECO-STAR EVACUATION SYSTEM	80
ESC-230	EKOM START CAPACITOR 230V	233
ESC-230	EKOM START CAP 230V	233
ESC-32	ECO-STAR EVACUATION SYSTEM	140
ESC-KIT	ECO-STAR EVACUATION SYSTEM	133
ESCD-100	ELITE SOUND COVER-DUAL COMPRESSOR	2,788
ESCRD-100	ELITE SOUND COVER-SINGLE COMPRESSOR	2,124
ESK-100	ELITE SERVICE KIT-ELITE COMP	260
ESK-200	ELITE SERVICE KIT-TRIPLE COMP	285
EVDC-1.25	CHECK VALVE ASSY 1-1/4 ECO VAC	524
EVDC-1.25	ECOVAC DUAL CHECK VALVE	524
EVF-100	ECO VAC FLOAT FOR TANK	369

TECH WEST RETAIL PRICE LIST - PARTS

PART NUMBER	DESCRIPTION	RETAIL PRICE
EVF-100	ECO VAC FLOAT F/TANK	369
EVMSC-100	SHIPPING BOX ECO VAC MOTOR	124
EVMSC-100	ECO VAC MTR SHIP BOX W/LINERS	124
EVRC-100	ECOVAC RELAY CONTROL	675
EVTC-100	ECO-VAC TIMER CONTROL	677
EVTC-14	14 GALLON TANK	3,040
EVTC-14	ECOVAC TANK CMPLT 14 GAL	3,040
EVTK-100	ECO-VAC TANDEM KIT TO MAKE TWO	837
EVTS-100	TGL SWITCH 20A,125V,10A/230V	29
FE-4-2	BRASS FLARE ELBOW 1/4 X 1/8	8
FE-4-4	BRASS FLARE ELBOW 1/4 X 1/4	12
FE-4-6	BRASS FLARE ELBOW 1/4 X 3/8	22
FE-6-4	BRASS FLAIR ELBOW 3/8 X 1/4	12
FE-6-6	BRASS FLARE ELBOW 3/8 MPTX3/8	7
FF-4-6	BRASS FLARE FITT. 1/4MPT X 3/8	47
FH-100	FUSE HOLDER, PUMP	29
FPH-1	PVC FLEXABLE HOSE - 1	9
FPH-1.25	PVC FLEXIBLE HOSE 1 1/4	17
FPH-375	PVC FLEXIBLE HOSE 3/8 CLEAR	3
FPH-750	PVC FLEXIBLE HOSE 3/4	9
GB-1.25-250	GALVANIZED BUSHING 1 1/4 X 1/4	30
GC-1.25	GALV COUPLING 1-1/4"	32
GN-1.25-CL	GALV NIPPLE 1-1/4 X CL	14
GN-125-3	GALV NIPPLE 1/8 X 3	12
GOM-075R-115	GAST OILLESS ROCKY MOTOR 3/4 HP-115V	3,595
GOM-075R-230	GAST OILLESS ROCKY MOTOR 3/4 HP-230V	3,595
GRRK-100	GAST ROCKY REBUILD KIT	837
HA-60-250	AIR/WATER HOSE, BLUE,60IN	82
HB-25-375	BRASS HOSE BARB 1/4 MPT X 3/8	24
HBE-4-6	BRASS HOSE BARB ELBOW	21

TECH WEST RETAIL PRICE LIST - PARTS

PART NUMBER	DESCRIPTION	RETAIL PRICE
HBE-6-8	HOSE BARB ELL 3/8MPT X 1/2BARB	12
ICO	INDUSTRIAL COMPRESSOR OIL	181
MB-1810	MOTOR BEARING FOR 1810 BLOWER	301
MB-6203	MOTOR BEARING 6203 SEALED	74
MB-6205	MOTOR BEARING 6205 SEALED	151
MG-100	MANIFOLD GASKET, PUMP	21
MI-100	MOISTURE INDICATOR	110
MSD-100	DESICCANT-MOLECULAR SIEVE	49
MSD-200	DESICCANT-ACTIVATED ALUMINA	64
MV-250	METERING VALVE FOR COMPRESSOR	137
MVA-250	METERING CHECK VALVE ASSEMBLY	125
OR-5	O-RING FOR PUMP BASE 5"	18
PC-1-S-S	PVC COUPLING 1 SXS	3
PE-750-SP	PVC ELBOW 3/4 SPIGOT X SLIP	7
PFE-4-2	BRASS POLY-FLO ELBOW 1/4 X 1/8	21
PFE-4-4	BRASS POLY-FLO ELBOW 1/4 X 1/4	18
PFT-250	POLY-FLO TUBE 1/4 BLUE	1
PHF-250	BRASS HOSE FITTING 1/4 PSH LCK	15
PLH-250	PUSHLOCK HOSE 1/4" BLUE	12
PMA-1.25	PVC MALE ADAPTOR 1 1/4	4
PMA-750	PVC MALE ADAPTER 3/4	7
PMG-VAC	PANEL MOUNT GAUGE DRY VACUUM	81
PN-1.25-2	PVC NIPPLE 1 1/4 X 2 SCH 80	12
POVA-100	POP OFF VALVE 125 PSI ASME	88
POVA-165	POP OFF VALVE 165 PSI	21
PR-100	PUMP RELAY	167
PR-230	RELAY, 230 V	132
PRB	PUMP RELAY BOX	91
PRC	PUMP RELAY COVER	83
PSC-115	PUMP SOLENOID COIL 115 VOLT	109

TECH WEST RETAIL PRICE LIST - PARTS

PART NUMBER	DESCRIPTION	RETAIL PRICE
PSC-250-E	PRESSURE SWITCH COMP	339
PSC-3	PRESSURE SWITCH COMP. 3 HP	248
PSC-750	PVC COUPLING 3/4 SXS	3
PSE-1.25-SP	PVC STREET ELL 1 1/4 SPGXS	18
PSE-1.25-TS	PVC STREET ELL 1 1/4" T X S	14
PSE-750-ST	PVC STREET ELBOW 3/4 SXT	3
PSE-750-TT	PVC STREET ELBOW 3/4 TXT	21
PSK-100	SHIM KT FOR VAC PUMP	113
PSS-100	PUMP SHAFT SEAL 5/8	51
PSV-115GC	PUMP SOLENOID VALVE 115 VOLT	243
PSV-115GC	SOLENOID	243
PSV-230	PUMP SOLENIOD VALVE 230 VOLT	243
PT-100	PUMP TRANSFORMER 24 VOLT	110
PTA-100	P-TRAP RACK	188
PTS-100	PUMP TOGGLE SWITCH 24 VOLT	33
PU-1250S	PVC UNION 1 1/4 SXS	108
PU-750S	PVC UNION 3/4 SXS	83
PU-750T	PVC UNION 3/4 TXT	83
PVB-100	PUMP VACUUM BREAKER WITH 1/4 X	373
PVB-100	VACUUM PUMP BREAKER	373
RCM-2	RUN CAPACITOR MAGNETEK 1.5 HP	138
RDC-100	REPLACEMENT DESSICANT TANK	912
RFEM-100	RUBBER FOOT FOR EKOM MOTORS	9
RFV-100	RUBBER FEET FOR AIR COMPRESSOR	24
RFVF-100	RUBBER FEET FOR VACUUM PUMP	24
RIC-GAST	RUBBER MOUNTING FOOT-GAST MOTOR	22
RMF-100	ROCKY COMPRESSOR MOTOR	29
RMF-100	ROCKY CMPRS MTR FT 1/4-20	29
RPB-SINGLE	REPL PUMP BOX SINGLE	57
RPB-SINGLE	REPLACEMENT PUMP BOX	57

TECH WEST RETAIL PRICE LIST - PARTS

PART NUMBER	DESCRIPTION	RETAIL PRICE
SBF-100	FUSE 1 AMP SLOW BLOW	79
SBF-250	SLOW BLOW FUSE 1/4 AMP, PUMP	8
SBHA-11-375E	STEEL BRAIDED HOSE 3/8X11	125
SBHA-15-375M	STEEL BRAID HOSE ASSY 15"	126
SBHA-16-375M	STEEL HOSE ASSY 3/8"X3/8" 8.5"	150
SBHA-22-375	STEEL BRAIDED HOSE ASSY 3/8X22	95
SCM-1	START CAPACITOR MAGNETEK 1 HP	159
SCM-2	START CAPACITOR MAGNETEK 1.5HP	159
SCR-230	START CAPACITOR ROCKY	95
SCV-1.25	BRASS CHECK VALVE 1 1/4 SWING	144
SN-250-CL	STAINLESS NIPPLE 1/4 CLOSE	7
SPS-100	SGL POLE SWITCH 115V CMPRSR	30
SSBP	STAINLESS STEEL BASE PLATE	384
SSIL-100	SS IMPELLER F/VAC PUMP	838
SSPH	SS IMPELLER F/VAC PUMP	990
STBD	SEPERATOR TANK BANDS, DUAL	108
STL-14	SEPARATOR LEGS FOR 14 GALLON	32
STS30-100	SEP TANK 30 GAL W/FLOAT	6,293
STS40-100	SEPARATOR TANK SS 40 GAL	8,007
SVF-100-I	SURG VAC FILTER ELEMENT INTAKE	82
SVFG-100	SURG VAC INTAKE FILTER	90
SVFH-100	HOLDER,SURG VAC FILTER	62
TIF-100	THOMAS AIR FILTER ELEMENT 1HP	51
TIF-200	THOMAS AIR FILTER ELEMENT 2HP	77
TS3	TERMINAL STRIP 3 POSITION	8
TS6	TERMINAL STRIP 6 POSITION	26
UCDC-100	ULTRACLEAN DESICCANT CARTRIDGE	731
VFA-1.25	VACUUM FILTER ASSEMBLY 1 1/4	203
VFA-100	VACUUM FILTER ASSEMBLY 1	181
VFA-40	VACUUM FILTER ASSEMBLY 3/4	137

TECH WEST RETAIL PRICE LIST - PARTS

PART NUMBER	DESCRIPTION	RETAIL PRICE
VFB-1.25	VACUUM FILTER BOWL 1 1/4	77
VFB-1.25	VACUUM FILTER BOWL 1 1/4	77
VFB-100	VACUUM FILTER BOWL 3/4"	58
VFB-100	FILTER BOWL	58
VFD-2-2	VFD DRIVE FOR 2 USER ECO-VAC	1,574
VFD-2-2	VFD,2 USER,TRANSDUCER	1,574
VFD-2-5	ECOVAC DRIVE 5USER W/TRANSDUCE	2,518
VFD-2-5	DRIVE,VFD,5 USER,ECO VAC	2,518
VFG-1.25	VACUUM FILTER GASKET 1 1/4	13
VFG-100	VACUUM FILTER GASKETS PKG. 4	30
VFG-100S	VACUUM FILTER GASKET 3/4"	15
VFG-100S	VACUUM FILTER GASKETS 3/4"	15
VFS-1.25	VACUUM FILTER SCREEN 1 1/4	41
VFS-125	VAC FILTER SCREEN 1 1/4	37
VFS-40	VACUUM SCREEN 40 MESH PK4	80
VFS-40	VACUUM SCREENS	80
VFS-40S	VACUUM SCREEN 40 MESH	21
VPG-100	VACUUM PUMP GAUGE	101
VPS-125	VACUUM PUMP STRAINER 1/8	123
VRV-100	VACUUM RELIEF VALVE FOR PUMP	124
VRV-100	VACUUM RELIEF VALVE	124
VT-100	VACUUM TRANSDUCER 0-30 HG	542
WB-100	WATER BYPASS 1IN NO FILTER	2,227
WFA-750	WATER FILTER BOWL/ASSEMBLY 3/4 (CLEAR)	137
WFB-1	WATER FILTER BOWL/ASSEMBLY 1 (BLUE)	293
WFB-750	WATER FILTER BOWL AND ORING	237
WFB-750	BOWL,WATER FILTER 3/4 IN	237
WFE-100	WATER FILTER ELEMENT 1 PKG OF 4	365
WFE-100E	REPLACEMNT WATER FILTER	87
WFE-750	WATER FILTER ELEMENT 3/4 PKG OF 4	182

TECH WEST RETAIL PRICE LIST - PARTS

PART NUMBER	DESCRIPTION	RETAIL PRICE
WFE-750E	WATER FILTER ELEMENT 3/4"	43
WFE-750S	WTR FILTER ELEMENT SGL 3/4"	33
WFOR-100	WATER FILTER O-RING 1	28
WFOR-750	WATER FILTER O-RING 3/4	21
WFW-100	WATER FILTER WRENCH 1	110
WFW-750	WATER FILTER WRENCH 3/4	60
WIA-100	WATER EJECTION ASSY COMPLETE	715
WIA-100	WATER INJECTION ASSY.	715
WIN-25-100	WATER INJECTION NOZZLE .25 GPM	125
WIN-75-100	WATER INJECTION NOZZLE .75 GPM	125
WMV-100	WATER BYPASS SOLENOID VALVE 1	1,120
WMV-750	WATER BYPASS SOLEN. VALVE 3/4	714
WMVC-750GC	WATER BYPASS SOLEN. VALVE COIL	159
WRC-100	WATER RECYCLER ASSEMBLY	158
WRC-100	WATER RECYCLER ASSY.	158
WRK-100	WATER RECYCLER KIT	482
WRK-100	WRK-100 WATER RECYCLER	482
WSA-100	WATER SHUTOFF ASSEMBLY DUAL	180



TECHWEST INC

Manufacturers of Dental Vacuum
and Air Systems

2657 N. Argyle Ave. • Fresno, CA 93727
(559) 291-1650 • (800) 428-7139
FAX (559) 348-9677
www.tech-west.com

Effective 3/26