



WE THINK GREEN!



TECHWEST_{INC}

2025 RETAIL CATALOG

TERMS AND CONDITIONS

Prices are subject to change without notice.

No returns are approved without first acquiring a return authorization (RMA) number. All returns are subject to a 15% restock charge. No returns are authorized after 60 days from the date of shipment.

Payment terms are cash with order or a net payment of 30 days on approved credit. A finance charge of 1 1/2% per month will be charged to an account over 30 days.

A credit line must be established on all open accounts.

Any customer who has allowed their account to become delinquent shall pay Tech West for all legal costs incurred during the necessary collection process.

Any customer allowing their account to become delinquent for extended periods beyond our normal terms will lose their privilege of selling the Tech West product line.

WARRANTY

Warranty service must be obtained through a Tech West, Inc. authorized dealer who carries the Tech West, Inc. product line for which warranty service is requested. It is the retail purchaser's obligation to arrange for delivery, at the retail purchaser's expense, of a product through its authorized dealers for warranty service. It is also the retail purchaser's obligation to comply with the warranty service instructions provided either by Tech West, Inc. or its authorized dealer.

Tech West warrants the original retail purchase within the warranty period of such specified product at Tech West, Inc.'s option to repair or replace components of dental products manufactured by Tech West, Inc. that are defective in material or workmanship under normal use and service. Tech West, Inc.'s obligation under this limited warranty is limited to the repair or replacement of the applicable components.

All part and component returns and replacement equipment under warranty require a Return Materials Authorization (RMA). Warranty returns must be received within 15 days of the RMA issue date. Items returned without an RMA, or included with other products for which an RMA has been issued, will be returned to the customer and no credit will be warranted.

Tech West, Inc. is not liable for indirect or consequential damages or loss of any nature in connection with this equipment. Warranty does not cover dealer labor, or shipping and handling charges inbound to Tech West, Inc. Warranty credit will not be applied to product returns that exhibit damage due to shipping, misuse, careless handling, or repairs by Dealer or unauthorized personnel. Credit, or partial credit, will not be issued until products/parts have been received and assessed. Any product is installed or serviced by anyone other than an authorized dealer or service personnel will void all possible warranties.

ALL PARTS HAVE A 90-DAY WARRANTY UNLESS OTHERWISE SPECIFIED.

WARRANTY FOR ALL EXPORT PRODUCT

All Tech West, Inc. products, i.e., vacuums, vacuum systems, and air compressors have a twelve-month or one-year manufacturer's warranty from the date of installation. Our warranty covers only defective parts covered under the warranty period. Labor or other services are excluded.

Warranty does not cover any misuse or improper installation of products. All installation(s) should be installed according to manufacturer installation guidelines. All warranties are evaluated before approval. Improper installations will void all warranties.

All warranty claims export end-users must contact their export distributors.

The terms, conditions, and warranties contained herein supersede all previous terms, conditions, and warranties, written, expressed, or implied, and are in effect January 1, 2024.



TECHWEST^{INC}

Table of Contents

Vacuum Pump Legend	pg. 2
EcoVac Systems	pg. 3
GoldenVac Systems	pg. 4
Evacuation System Cleaners	pg. 5
Air Compressor Legend	pg. 6
Elite Series Oilless Compressors	pg. 7
The Elite Series Oilless Rocky Compressors	pg. 8
Control Panels	pg. 9
Equipment & Accessories	pg. 10-12
Parts List	pg. 13-19

Remittance Address: 2657 N. Argyle Ave. • Fresno, CA 93727
Shipping Address: 2625 N. Argyle Ave. • Fresno, CA 93727
(559) 291-1650 • (800) 428-7139 • FAX (559) 348-9677
www.tech-west.com

MODEL NUMBER LEGENDS FOR VACUUM PUMPS

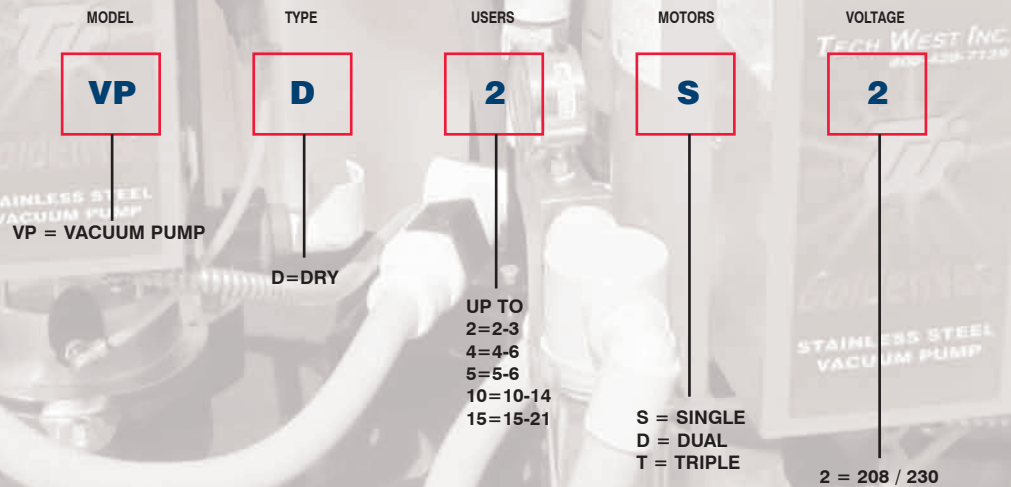
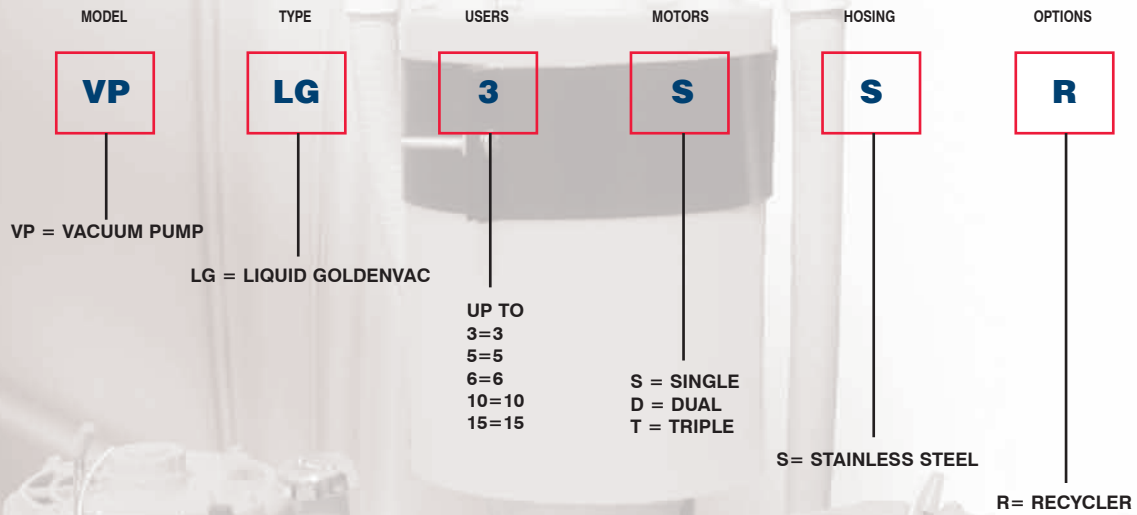

TECH WEST ECOVAC VACUUM PUMP

Our EcoVac system provides the advantages of proven technology, durable construction, quiet operation, and oil-free performance with the latest in water and energy-saving features. This is not only important to you as an environmentally responsible business owner, but it also prepares your practice for the upcoming change to metered water usage in many areas of the country. We utilize a Variable Frequency Drive (VFD) to control the vacuum levels. With no suction being used, the motor is running one-third the speed and using very little power. Every time a suction hose is being used the motor automatically speeds up to maintain constant suction.



Maintenance-free unit with no traps to clean, no oil to check or change. Truly a ZERO maintenance machine.

ECOVAC SYSTEMS

MODEL NUMBER	MAX USERS	# OF HEADS	TOTAL H.P.	CFM @ 8 HG	TANK GALLONS	VOLTAGE	TOTAL AMPS	BREAKER SIZE	DB(A)	EQUIP. WEIGHT	EQUIP. HEIGHT	EQUIP. WIDTH	EQUIP. DEPTH	SHIPPING WEIGHT	SHIPPING HEIGHT	SHIPPING WIDTH	SHIPPING DEPTH	LIST PRICE
VPD2S2	2-3	1	2	20	14	208/230	5	20	60	139	52	23	20	220	44	42	31	14,876
VPD2S2-NT	2-3	1	2	20	N/A	208/230	5	20	60	139	52	23	20	220	44	42	31	13,928
VPD5S2	5-7	1	2	45	14	208/230	7	20	62	139	52	23	20	220	44	42	31	16,587
VPD5S2-NT	5-7	1	2	45	N/A	208/230	7	20	62	139	52	23	20	220	44	42	31	15,784
VPD4D2	4-6	2	4	40	14	208/230	10	2X20	62	282	39	40	20	350	44	42	31	27,207
VPD10D2	10-14	2	4	90	30	208/230	14	2X20	62	282	39	40	20	325	44	43	31	31,009
VPD10D2-14	10-14	2	4	90	14	208/230	14	2X20	62	350	39	43	31	350	45	31	43	31,009
VPD10D2-NT	10-14	2	4	90	N/A	208/230	14	2X20	62	350	45	43	31	350	45	31	43	28,601
VPD15T2	15-21	3	6	110	40	208/230	21	3X20	62	402	60	40	20	455	44	42	31	47,219

DVU-S Upgrade 2-3 user single to 5-7 user: 2,949

DVU-D Upgrade 4-6 user dual to 10-14 user: 5,900

(VPD10D2 has a 30 gallon tank. Tank weight: 157 lbs. Tank dimensions: 27"W x 28"D x 61"H)

5 YEAR WARRANTY OR 5000HRS ON MOTOR, 2 YEARS WARRANTY ON ALL OTHER COMPONENTS

FDA
RECOGNIZED

Meets or exceeds NFPA applicable guidelines

www.tech-west.com

TECH WEST

GOLDENVAC STAINLESS STEEL VACUUM PUMP



The Tech West GoldenVac has proved to be the industry leader in design and performance. A vacuum system you can rely on for years to come. All GoldenVac vacuum pumps have an exclusive warranty with 10 years on all stainless steel pump parts, 5 years on the motor shaft and all other components come with a 3 year warranty. GoldenVac vacuum pumps have an investment cast stainless steel impeller with a radical new design that improves performance by 20% over other pumps. The stainless steel castings provide maximum durability to prevent wear from air abrasion and ceramic particles, or hard water conditions. All motors are thermally protected and are cap-start, and cap-run. This will lower the electrical consumption of the pump. Water recyclers and air-water separators are available for all pumps. The GoldenVacs are available in single, dual, or triple configurations. Tech West will provide plumbing and electrical designs upon request.

GOLDENVAC SYSTEMS

MODEL NUMBER	# OF USERS	VOLTAGE	BREAKER SIZE	H.P.	AIR/WATER SEP	DB(A)	EQUIP. HEIGHT	EQUIP. DEPTH	EQUIP. WIDTH	EQUIP. WEIGHT	SHIPPING HEIGHT	SHIPPING DEPTH	SHIPPING WIDTH	LIST PRICE	
VPLG3SS	3	115/230	20	1	NO	70	18	13	13	73	22	18	18	85	4,338
VPLG3SSR	3	115/230	20	1	NO	70	18	13	13	75	22	18	18	87	4,512
VPLG5SS	5	208/230	20	2	NO	70	18	13	13	89	22	18	18	85	5,387
VPLG5SSR	5	208/230	20	2	NO	70	18	13	13	91	22	18	18	87	5,625
VPLG6D2	6	208/230	2X20	2X1	YES	72	30	20	28	197	34	21	37	210	9,338
VPLG6D2R	6	208/230	2X20	2X1	YES	72	30	20	28	200	34	23	37	212	9,678
VPLG10D2	10	208/230	2X20	2X2	YES	72	30	20	28	227	34	23	37	221	11,148
VPLG10D2R	10	208/230	2X20	2X2	YES	72	30	20	28	230	34	23	37	223	11,627
VPLG15T2	15	208/230	3X20	3X2	YES	74	30	20	41	213	34	23	49	298	16,060
VPLG15T2R	15	208/230	3X20	3X2	YES	74	30	20	41	215	34	23	49	300	17,184

WARRANTY: 10 YEARS ON STAINLESS STEEL PARTS, 5 YEARS ON MOTOR SHAFT,
3 YEARS ON ALL OTHER COMPONENTS

FDA
RECOGNIZED

Meets or exceeds NFPA applicable guidelines

TECH WEST EVACUATION SYSTEM CLEANER



Evacuation System Cleaner

The amount of waste residue (Biofilm/plaque) slogging down your evacuation system depends on the age of your facility, water supply pH, chemical cleaner in use, and how much/often it was used. The Restore Protocol will release the Biofilm/plaque material from the inside of your lines/pipes.

Tech West's Microbial Formula digests organic matter and solids which **GUARANTEES TO MAINTAIN SUCTION PERFORMANCE** and "ELIMINATE" Daily Trap Hand Cleaning. 100% All Natural & Biodegradable. Non-Foaming & SAFE for humans, animals, plants, and pipes.

EcoStar-eVac Cleaner comes in two different sizes and the initial amount used to restore the system depends on the age of the system. Detailed instructions are available upon request. It is recommended that EcoStar-eVac Cleaner be used to maintain your system once it is initially cleaned. This will insure cleanliness and long life of the system.

PART#	DESCRIPTION		LIST PRICE
ESC-16	EcoStar-eVac Cleaner	16 oz.	76
ESC-32	EcoStar-eVac Cleaner	32 oz.	134
ESC-KIT	EcoStar HVE & Si Dispenser	16 oz.	126

Note: It is recommended to use 4 oz / chair per month

MODEL NUMBER LEGENDS FOR AIR COMPRESSORS

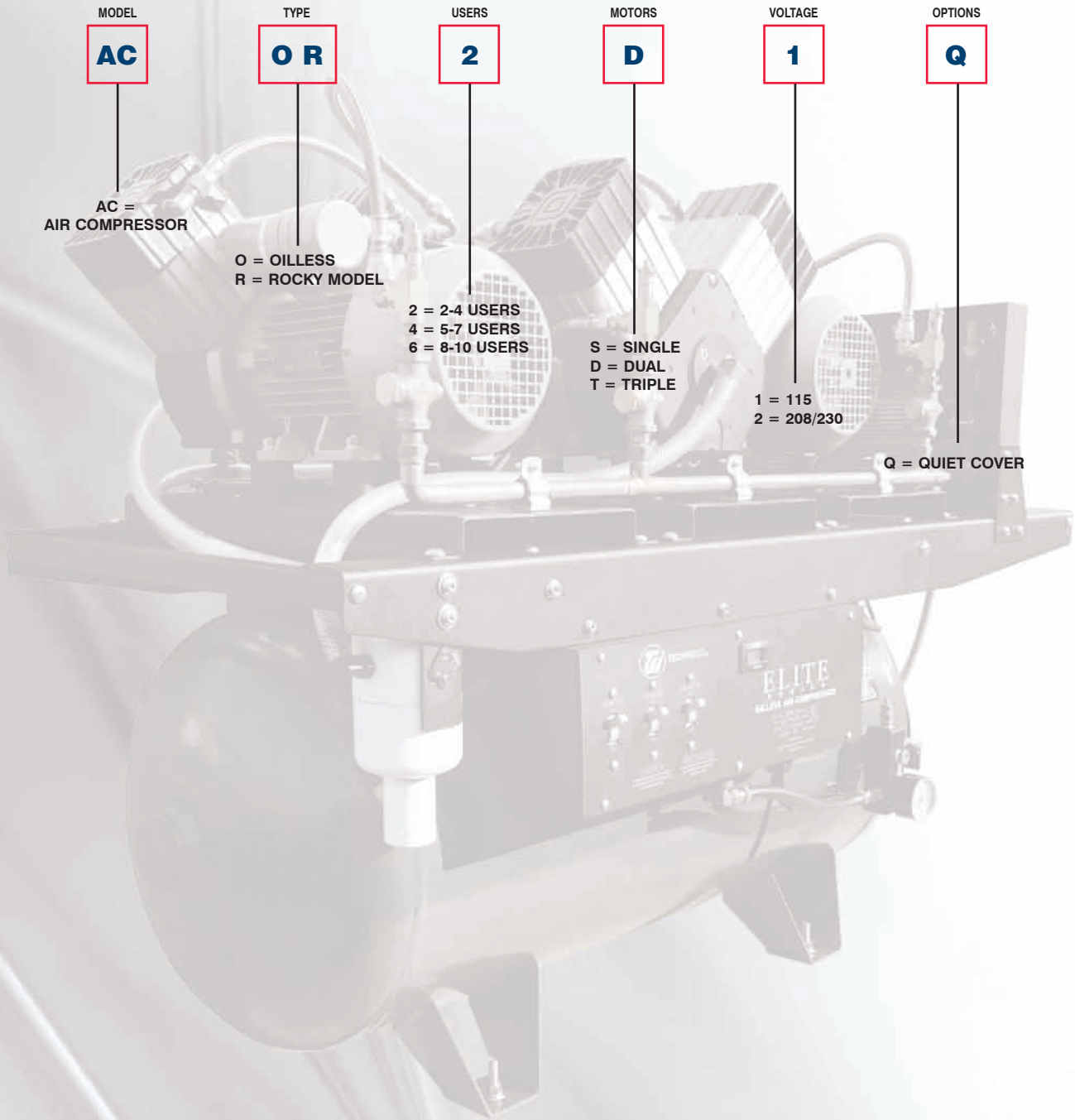

TECH WEST

ELITE SERIES ULTRA CLEAN OILLESS COMPRESSOR

Our Elite Series Oilless Air Compressor system provides the advantages of proven technology, durable construction, quiet operation, and oil-free performance with the latest in energy-saving features. This is important to you as an environmentally responsible business owner.

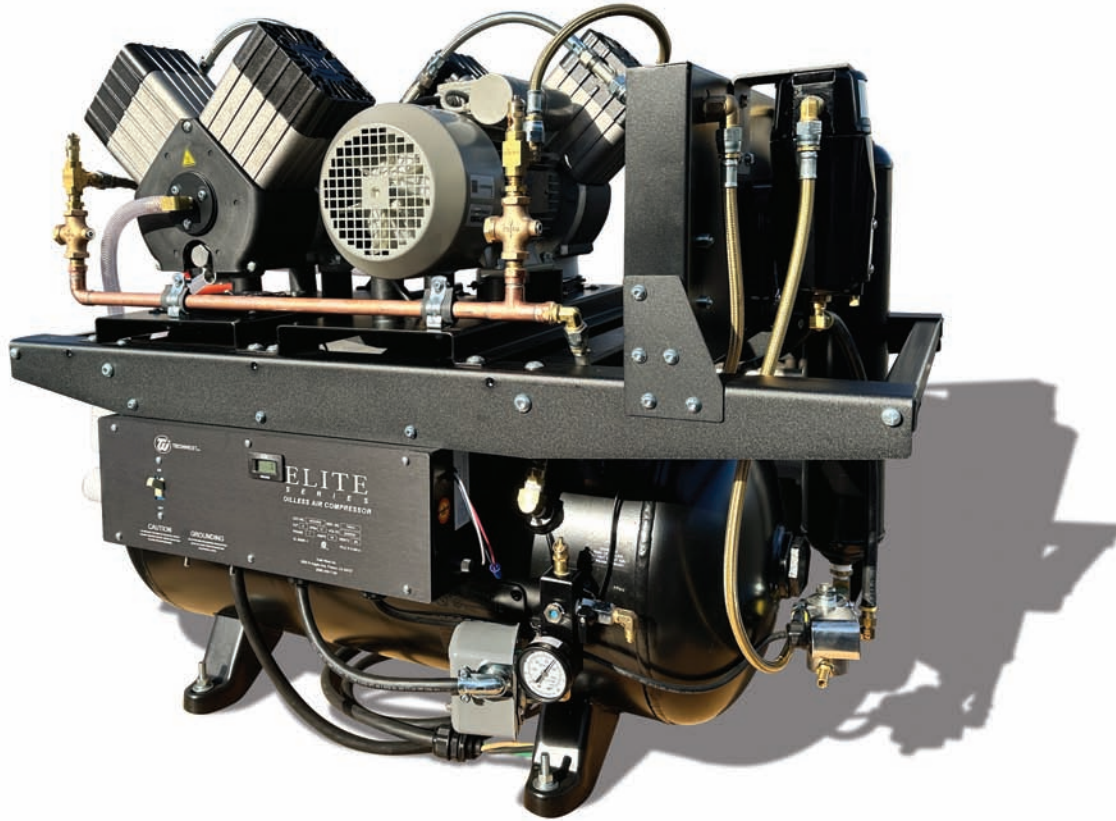

OILLESS AIR COMPRESSORS

MODEL NUMBER	MAX USERS	AIR DRYER	QUIET COVER	# OF HEADS	TOTAL H.P.	CFM	TANK GALLONS	VOLTAGE	TOTAL AMPS	BREAKER SIZE	DB(A)	EQUIP. WEIGHT	EQUIP. HEIGHT	EQUIP. WIDTH	EQUIP. DEPTH	SHIPPING WEIGHT	SHIPPING HEIGHT	SHIPPING WIDTH	SHIPPING DEPTH	LIST PRICE
ACO2S2	2-3	YES	NO	1	1.5	5.5	10	208/230	8	20	70	180	30	28	20.5	220	37	34	28	9,536
ESCRD-100	OPTIONAL QUIET COVER FOR THE ACO2S2										68	50	15	19	19	50	19	33	19	2,023
ACO4D2	5-7	YES	NO	2	3	11	20	208/230	16	30	72	248	34	38	22	335	44	42	30	14,164
ACO6T2	8-10	YES	NO	3	4.5	16.5	30	208/230	25.5	40	74	320	36	46	25	368	45	48	33	19,476
ESCD-100	QUIET COVER: OPTIONAL FOR THE ACO4D2										68	50	17	29	22	50	21	27	23	2,655

A 5 YEAR OR 3500 HR MOTOR WARRANTY. ALL OTHER COMPONENTS CARRY A 2 YEAR WARRANTY

Meets or exceeds NFPA applicable guidelines

FDA
RECOGNIZED

TECH WEST

ELITE SERIES ROCKY OILLESS AIR COMPRESSOR

The Tech West Rocky Series Oilless Air Compressors provide 100% oil-free air to the dental office. With our high-performance air drying system, we guarantee the clean dry air you expect. The design of the Tech West Rocky Series Air Compressor provides smooth, quiet, vibration-free operation at only 65 dB-a noise level. We offer them in a twin configuration to meet almost any need of today's Dental Practice. Tech West will provide full plumbing and electrical design upon request.

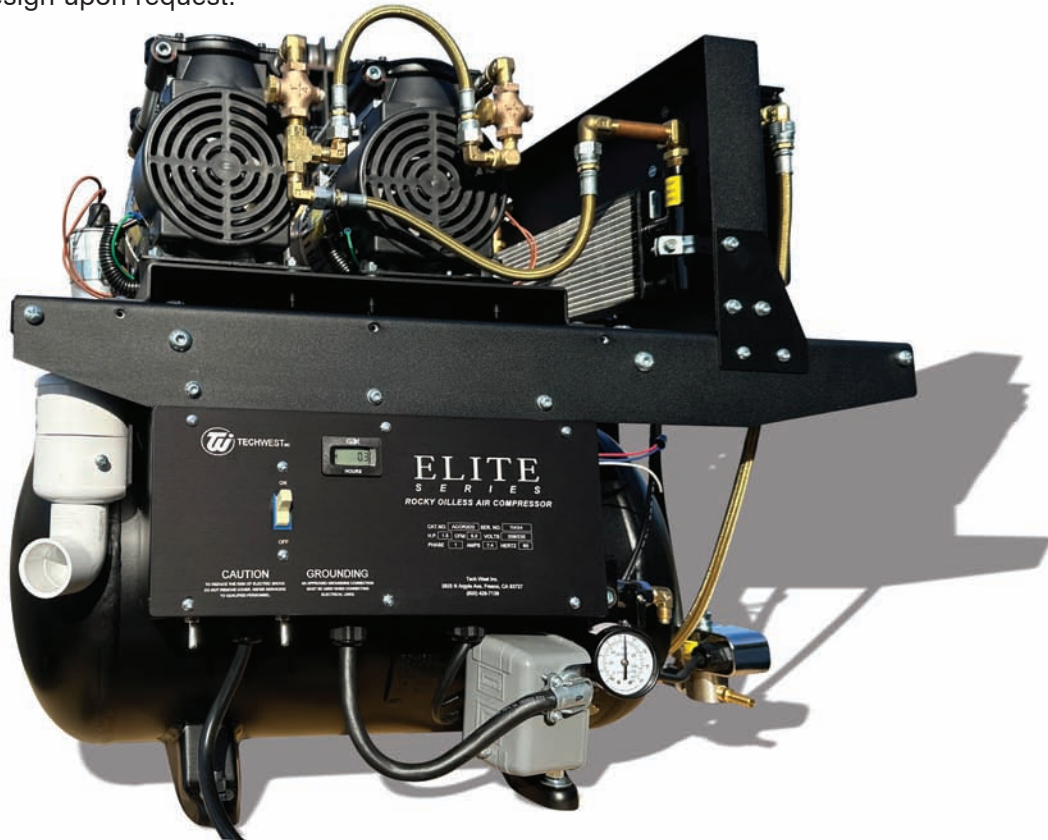

ROCKY OILLESS AIR COMPRESSORS

MODEL NUMBER	MAX USERS	AIR DRYER	QUIET COVER	# OF HEADS	TOTAL H.P.	CFM	TANK GALLONS	VOLTAGE	TOTAL AMPS	BREAKER SIZE	DB(A)	EQUIP. WEIGHT	EQUIP. HEIGHT	EQUIP. WIDTH	EQUIP. DEPTH	SHIPPING WEIGHT	SHIPPING HEIGHT	SHIPPING WIDTH	SHIPPING DEPTH	LIST PRICE
ACOR2D1	2-3	YES	NO	2	1.5	5.2	10	115	11	20	68	175	28	28	20.5	220	37	34	28	9,808
ACOR2D1Q	2-3	YES	YES	2	1.5	5.2	10	115	11	20	64	210	31	28	20.5	220	37	34	28	11,036
ACOR2D2	2-3	YES	NO	2	1.5	5.2	10	208/230	8	20	68	175	28	28	20.5	220	37	34	28	9,808
ACOR2D2Q	2-3	YES	YES	2	1.5	5.2	10	208/230	8	20	64	210	31	28	20.5	220	37	34	28	11,036

A 5 YEAR 3500 HOUR MOTOR WARRANTY. ALL OTHER COMPONENTS CARRY A 2 YEAR WARRANTY.

Meets or exceeds NFPA applicable guidelines

FDA
RECOGNIZED

TECH WEST

REMOTE CONTROL PANELS

Tech West's Remote Control Panels offer a wide variety of different models to suit almost any need. All the panels are brushed aluminum with a clear anodized coating that can be mounted onto standard electrical junction boxes.



PART #	DESCRIPTION	HEIGHT	WIDTH	RETAIL PRICE
CP-1V	CONTROL PANEL 1 VAC	4 1/2	4 1/2	279
CP-1V1A	CONTROL PANEL 1 VAC 1 AIR	4 1/2	4 1/2	525
CP-1V1A1W	CONTROL PANEL 1 VAC 1 AIR 1 H2O	4 1/2	6 1/2	664
CP-2A1W	CONTROL PANEL 2 AIR 1 H2O	4 1/2	6 1/2	701
CP-2V	CONTROL PANEL 2 VAC	4 1/2	4 1/2	525
CP-2V1A	CONTROL PANEL 2 VAC 1 AIR	4 1/2	6 1/2	701
CP-2V1A1W	CONTROL PANEL 2 VAC 1 AIR 1 H2O	4 1/2	6 1/2	805
CP-3V	CONTROL PANEL 3 VAC	4 1/2	6 1/2	701
CP-3V1A	CONTROL PANEL 3 VAC 1 AIR	4 1/2	6 1/2	701
CP-3V1A1W	CONTROL PANEL 3 VAC 1 AIR 1 H2O	4 1/2	6 1/2	875
CP-4V	CONTROL PANEL 4 VAC	4 1/2	6 1/2	701
CPB-100	CONTROL PANEL BULB (3PK)	N/A	N/A	58

CONTROL PANELS CARRY A 2 YEAR WARRANTY

TECH WEST WATER MANIFOLDS

Tech West's Water Manifolds offer safe after-hours protection for today's dental offices. Just push a button on the remote control panel and the water is off. Manifolds are available with or without a filter and with or without a low voltage contactor. The 3/4" unit has a clear filter housing and the 1" has a blue housing.



PART #	DESCRIPTION	HEIGHT	WIDTH	DEPTH	WEIGHT	RETAIL PRICE
WB-100	WTR BYPASS 1" NO FILTER	13	19	4	16	2,121
WB-100-RC	WTR BYPASS 1" NO FILTER W/RELAY	13	19	4	22	2,314
WB-750	WTR BYPASS 3/4" NO FILTER	10	15 1/2	4	13	1,252
WB-750-RC	WTR BYPASS 3/4" NO FILTER W/RELAY	10	15 1/2	4	18	1,541
WBF-100	WTR BYPASS FILTER 1" NO RELAY	24	25	7 1/2	25	2,507
WBF-100-RC	WTR BYPASS FILTER 1" W/RELAY	24	25	7 1/2	31	2,896
WBF-750	WTR BYPASS FILTER 3/4" NO RELAY	21	19 1/2	6	15	1,639
WBF-750-RC	WTR BYPASS FILTER 3/4" W/RELAY	21	19 1/2	6	18	1,929

PART #	DESCRIPTION	WEIGHT	RETAIL PRICE
WFE-750	3/4" FILTER ELEMENT PKG OF 4	3	174
WFE-100	1" FILTER ELEMENT PKG OF 4	8	348

TECH WEST WATER MANIFOLDS HAVE A FULL 2 YEAR WARRANTY

TECH WEST PUMP ACCESSORIES



WATER RECYCLER

Tech West's water recycler is a simple yet effective way to save as much as 70% of water consumption. It is factory installed on the pump or can be field installed with ease.

PART#	DESCRIPTION	PRICE
WRK-100	WATER RECYCLER KIT	459

P-TRAP ADAPTER

The P-Trap adapter is designed to be used with all Whirlwind/Goldenvac Pump models with exhaust separators. The separator waste connection may be hooked to the P-Trap Adapter without worry of splash or vapor contamination. It includes a 1 1/2" ABS slip connection to P-Trap, a stainless steel bridge assembly with 90 degree PVC elbow and adapters for 3/4 drain flex lines.



PART#	PRICE
PTA-100	179

STACKING RACK

The stacking rack is designed to reduce the space required to install vacuum and air equipment by about half. The space savings is achieved by placing the stacking rack over your compressor and installing your platform mounted Whirlwind/Goldenvac pumps on the rack. The stacking rack fits both the dual and triple vacuum systems.



PART #	HEIGHT	WIDTH	DEPTH	WEIGHT	RETAIL PRICE
SR-100	39	43	27	75	1,227

AIR WATER SEPARATOR WITH VAPOR STOP

Air-water separators are available in single, dual, and triple models. They are designed to separate the liquids entrained in the exhaust. A vapor-stop fitting allows the liquids to create a gas and vapor trap, thereby eliminating odors and contaminants from entering the equipment location. All models include vapor-stop, hoses, fittings, P-trap adapter and a mounting bracket.



PART #	DESCRIPTION	HEIGHT	WIDTH	DEPTH	WEIGHT	RETAIL PRICE
ES-1	SINGLE	16	16	9	18	730
ES-2	DUAL	16	16	9	18	838
ES-3	TRIPLE	16	16	11	18	944

TECH WEST ACCESSORIES

COMPRESSOR OIL

Our compressor oil is specially formulated for our oil lubricated compressors. It is a very high grade of synthetic lubricant with an additive to help reduce piston friction and wear.



PART# CO-100 PRICE 79
(Case of 4)

RELAY CONTROL 24V/115-230V

For 24V remote switching of compressors, water manifolds, and other electrical devices. Relay provides 40 amp. resistive load capability, 30VA and 24 VAC transformer. Fused on 24V side.



PART#	DESCRIPTION	PRICE
RC-115	115V RELAY CONTROL	396
RC-230	230V RELAY CONTROL	396

BOOST TRANSFORMER

When line voltage at an installation site is below 208 volts for a pump or compressor, it is recommended that a boost transformer be installed. They are pre-wired for quick installation. Select your booster based on the total horsepower of your pump or compressor. All dual and triple-model Whirlwinds should use individual boosters for each vacuum pump or separate circuits.



PART #	DESCRIPTION	WEIGHT	RETAIL PRICE
BT-2-230	2 HP 230 V.	18	1,051
BT-3-230	3 HP 230 V.	23	1,227

BOOST TRANSFORMERS CARRY A 2 YEAR WARRANTY

TECH WEST RETAIL PRICE LIST - PARTS

PART NUMBER	DESCRIPTION	RETAIL PRICE
AS-500	AIR STONE 1/2MPT x 3/8FPT	113
BB-6-4	BRASS BUSHING 3/8 x 1/4	11
BN-125-CL	BRASS NIPPLE 1/8 CLOSE	3
BN-250-1.50	BRASS NIPPLE 1/4 X 1 1/2	21
BN-250-CL	BRASS NIPPLE 1/4 CLOSE	3
BN-6-CL	BRASS NIPPLE 3/8 CLOSE	4
BN-750-2	BRASS NIPPLE 3/4 x 2	28
BN-750-CL	BRASS NIPPLE 3/4 CLOSE	20
BPC-4	BRASS PIPE CROSS 1/4	33
BPP-4	BRASS PIPE PLUG 1/4	3
BRN-4-2	BRASS REDUCER NIPPLE 1/4 x 1/8	9
BSE-2	BRASS STREET ELBOW 1/8	18
BSE-250	BRASS STREET ELBOW 1/4	9
BT-250	BRASS TEE 1/4	21
BV-250-FM	BALL VALVE 1/4 FEMALE TO MALE	21
CF-115-230E	COOLING FAN DUAL VOLTAGE 115/230VLT	130
CFAO-375	COALESCING FILTER ASSEMBLY 3/8	600
CFB-P	COALESCING FILTER BRACKET	41
CFBP	COALESCING FILTER BOWL PARKER	385
CFE-375	COAL FILTER ELEMENT #18 .01MIC	199
CFEO-375	COAL FILTER ELEMENT PARKER	199
CFG-100	COOLING FAN FINGER GUARD	20
CFSG-100	COALESCING FILTER SIGHT GLASS	118
CPS-100V	CONTROL PANEL SWITCH	330
CPS-100VS	CONTROL PANEL SWITCH	181
CPSLA-100	CONTROL PANEL SWITCH LENS-AIR	54
CPSLH-100	CONTROL PANEL SWITCH LENS-H20	54
CPSLV-100	CONTROL PANEL SWITCH LENS-VACUUM	54
CPSV-100	CONTROL PANEL SWITCH-VACUUM	204
CSKL-1	COMP. SERVICE KIT, SINGLE LUB WILKERSON BOWL	255

TECH WEST RETAIL PRICE LIST - PARTS

PART NUMBER	DESCRIPTION	RETAIL PRICE
CSKL-1P	COMP. SERVICE KIT, SINGLE LUB PARKER BOWL	255
CSKL-2	COMP. SERVICE KIT, DUAL LUB WILKERSON BOWL	275
CSKL-2P	COMP. SERVICE KIT, DUAL LUB PARKER BOWL	373
CSKL-3	COMP. SERVICE KIT, TRIPLE LUB WILKERSON BOWL	316
CSKL-3P	COMP. SERVICE KIT, TRIPLE LUB PARKER BOWL	316
CSKO-1	COMP. SERVICE KIT, SINGLE OILLESS WILKERSON BOWL	300
CSKO-1P	COMP. SERVICE KIT, SINGLE OILLESS PARKER BOWL	300
CSKO-2	COMP. SERVICE KIT, DUAL OILLESS WILKERSON BOWL	376
CSKO-2P	COMP. SERVICE KIT, DUAL OILLESS PARKER BOWL	376
CSKO-3	COMP. SERVICE KIT, TRIPLE OILLESS WILKERSON BOWL	478
CSKO-3P	COMP. SERVICE KIT, TRIPLE OILLESS PARKER BOWL	478
CV-250	BRASS CHECK VALVE 1/4 SPRING	109
CV-250D	1/4" CHECK VALVE MNPT X MNPT	59
CV-375	BRASS CHECK VALVE 3/8 SPRING	115
CV-375MF	BRASS CHECK VALVE 3/8 MF	94
CVF-1.25	PVC CHECK VALVE 1 1/4-FLO	105
CVF-750	PVC CHECK VALVE 3/4-FLO	78
CVK-750	PVC CHECK VALVE 3/4-KING	94
CVP-15M	CENTRIFUGAL VACUUM PUMP 15HP	40,448
CVP-75M	CENTRIFUGAL VACUUM PUMP 7.5HP	26,260
DC-250	BRASS DRAINCOCK 1/4	18
DCV-100	DUAL VAC PUMP CHECK VALVE ASSY	360
DSVM	MOTOR 3/4 HP SURGICAL VAC	4,791
DDSK-100	DRYER DESICANT SERVICE KIT	210
DPA-100	DUAL PLATFORM ASSEMBLY	1,374
DPB-100	DRYER PURGE BUCKET 2 GAL W/LID	33
DSV-115	DRYER SOLENOID VALVE 115 VOLT	370
DSV-230	DRYER SOLENOID VALVE 230 VOLT	370
DVEH-2	DRY VAC EXHAUST HOSE 2	31
DVU-D	UPGRADE 4-6 USER DUAL TO 10-14 USER	5,900

TECH WEST RETAIL PRICE LIST - PARTS

PART NUMBER	DESCRIPTION	RETAIL PRICE
DVU-S	UPGRADE 203 USER SINGLE TO 5-7 USER	2,949
EDT-100	ELITE DESICCANT TANK W/ DESICCANT BEADS	1,031
EC-115	EXTENSION CORD 6FT 115V	26
EC-230	EXTENSION CORD 6FT 230V	30
EOM-1.50-230	ELITE OILLESS MOTOR 1.5HP/115V W/MOTOR MOUNT	5,596
EOM-150-230V	ELITE OILLESS MOTOR 1.5 HP/230 V 60HZ	4,593
ES-1	SINGLE SEPERATOR WITH VAPOR STOP	730
ES-2	DUAL SEPERATOR WITH VAPOR STOP	838
ES-3	TRIPLE SEPERATOR WITH VAPOR STOP	944
ESC-16	ECO-STAR EVACUATION SYSTEM	76
ESC-32	ECO-STAR EVACUATION SYSTEM	134
ESK-100	ELITE SERVICE KIT-ELITE COMP	248
ESK-200	ELITE SERVICE KIT-TRIPLE COMP	271
ESC-KIT	ECO-STAR EVACUATION SYSTEM	126
ESCRD-100	ELITE SOUND COVER-SINGLE COMPRESSOR	2,023
ESK-100	ELITE SERVICE KIT-ELITE COMP	248
ESK-200	ELITE SERVICE KIT-TRIPLE COMP	271
EVTC-100	ECO-VAC TIMER CONTROL	645
EVTK-100	ECO-VAC TANDEM KIT TO MAKE TWO	798
FE-4-2	BRASS FLARE ELBOW 1/4 x 1/8	8
FE-4-4	BRASS FLARE ELBOW 1/4 x 1/4	11
FE-4-6	BRASS FLARE ELBOW 1/4 x 3/8	21
FE-6-4	BRASS FLAIR ELBOW 3/8 x 1/4	11
FE-6-6	BRASS FLARE ELBOW 3/8 MPTx3/8	6
FF-4-6	BRASS FLARE FITT. 1/4MPT x 3/8	45
FH-100	FUSE HOLDER, PUMP	28
FPH-1	PVC FLEXABLE HOSE - 1	9
FPH-1.25	PVC FLEXIBLE HOSE 1 1/4	16
FPH-375	PVC FLEXIBLE HOSE 3/8 CLEAR	3
FPH-750	PVC FLEXIBLE HOSE 3/4	9

TECH WEST RETAIL PRICE LIST - PARTS

PART NUMBER	DESCRIPTION	RETAIL PRICE
GN-125-3	GALV NIPPLE 1/8 X 3	11
GOM-075R-115	GAST OILLESS ROCKY MOTOR 3/4 HP-115V	3,424
GOM-075R-230	GAST OILLESS ROCKY MOTOR 3/4 HP-230V	3,424
GRRK-100	GAST ROCKY REBUILD KIT	798
HB-25-375	BRASS HOSE BARB 1/4 MPT x 3/8	23
HBE-6-8	HOSE BARB ELL 3/8MPT x 1/2BARB	11
ICO	INDUSTRIAL COMPRESSOR OIL	173
MB-1810	MOTOR BEARING FOR 1810 BLOWER	286
MB-6203	MOTOR BEARING 6203 SEALED	70
MB-6205	MOTOR BEARING 6205 SEALED	144
MG-100	MANIFOLD GASKET, PUMP	20
MI-100	MOISTURE INDICATOR	105
MSD-100	DESICCANT-MOLECULAR SIEVE	46
MSD-200	DESICCANT-ACTIVATED ALUMINA	61
OR-5	O-RING FOR PUMP BASE 5"	18
PC-1-S-S	PVC COUPLING 1 SxS	3
PE-750-SP	PVC ELBOW 3/4 SPIGOT x SLIP	6
PFE-4-2	BRASS POLY-FLO ELBOW 1/4 X 1/8	20
PFE-4-4	BRASS POLY-FLO ELBOW 1/4 x 1/4	18
PFT-250	POLY-FLO TUBE 1/4 BLUE	1
PMA-1.25	PVC MALE ADAPTOR 1 1/4	4
PMA-750	PVC MALE ADAPTER 3/4	6
PMG-VAC	PANEL MOUNT GAUGE DRY VACUUM	78
PN-1.25-2	PVC NIPPLE 1 1/4 X 2 SCH 80	11
POVA-100	POP OFF VALVE 125 PSI ASME	84
POVA-165	POP OFF VALVE 165 PSI	20
PR-100	PUMP RELAY	159
PRB	PRB PUMP RELAY BOX	86
PRC	PRC PUMP RELAY COVER	79
PSC-115	PSC-115 PUMP SOLENOID COIL 115 VOLT	104

TECH WEST RETAIL PRICE LIST - PARTS

PART NUMBER	DESCRIPTION	RETAIL PRICE
PSC-3	PSC-3 PRESSURE SWITCH COMP. 3 HP	236
PSC-250-E	PSC-250-E PRESSURE SWITCH COMP	323
PSC-750	PSC-750 PVC COUPLING 3/4 SxS	3
PSE-1.25-SP	PSE-1.25-SP PVC STREET ELL 1 1/4 SPGxS	18
PSE-750-ST	PSE-750-ST PVC STREET ELBOW 3/4 SxT	3
PSE-750-TT	PSE-750-TT PVC STREET ELBOW 3/4 TxT	20
PSS-100	PSS-100 PUMP SHAFT SEAL 5/8	49
PSV-115GC	PSV-115GC PUMP SOLENOID VALVE 115 VOLT	231
PSV-230	PSV-230 PUMP SOLENIOD VALVE 230 VOLT	231
PTA-100	PTA-100 P-TRAP RACK	179
PT-100	PT-100 PUMP TRANSFORMER 24 VOL	105
PTS-100	PTS-100 PUMP TOGGLE SWITCH 24 VOLT	31
PU-1250S	PU-1250S PVC UNION 1 1/4 SxS	103
PU-750S	PU-750S PVC UNION 3/4 SxS	79
PU-750T	PU-750T PVC UNION 3/4 TxT	79
PVB-100	PVB-100 PUMP VACUUM BREAKER WITH 1/4 X	355
RCM-2	RCM-2 RUN CAPACITOR MAGNETEK 1.5 HP	131
RFV-100	RFV-100 RUBBER FEET FOR AIR COMPRESSOR	23
RFVF-100	RFVF-100 RUBBER FEET FOR VACUUM PUMP	23
RIC-GAST	RIC-GAST RUBBER MOUNTING FOOT-GAST MOTOR	21
RDC-100	RDC-100 REPLACEMENT DESSICANT TANK	869
SBHA-14-375	SBHA-14-375 STEEL BRAID HOSE ASSY 3/8 X 14	3
SBF-250	SBF-250 SLOW BLOW FUSE 1/4 AMP, PUMP	8
SCM-1	SCM-1 START CAPACITOR MAGNETEK 1 HP	151
SCM-2	SCM-2 START CAPACITOR MAGNETEK 1.5HP	151
SCR-230	SCR-230 START CAPACITOR ROCKY	90
SCV-1.25	SCV-1.25 BRASS CHECK VALVE 1 1/4 SWING	138
SN-250-CL	SN-250-CL STAINLESS NIPPLE 1/4 CLOSE	6
STBD	STBD SEPERATOR TANK BANDS, DUAL	103
TIF-100	TIF-100 THOMAS AIR FILTER ELEMENT 1hp	49

TECH WEST RETAIL PRICE LIST - PARTS

PART NUMBER	DESCRIPTION	RETAIL PRICE
TIF-200	TIF-200 THOMAS AIR FILTER ELEMENT 2hp	74
TS3	TS3 TERMINAL STRIP 3 POSITION	8
TS6	TS6 TERMINAL STRIP 6 POSITION	25
UCDC-100	UCDC-100 ULTRACLEAN DESICCANT CARTRIDGE	696
VFA-1.25	VACUUM FILTER ASSEMBLY 1 1/4	194
VFA-100	VACUUM FILTER ASSEMBLY 1	173
VFA-40	VACUUM FILTER ASSEMBLY 3/4	130
VFB-1.25	VFB-1.25 VACUUM FILTER BOWL 1 1/4	74
VFG-1.25	VACUUM FILTER GASKET 1 1/4	13
VPG-100	VACUUM PUMP GAUGE	29
VFS-1.25	VACUUM FILTER SCREEN 1 1/4 80# MESH	39
VFS-125	VACUUM FILTER SCREEN 1 1/4 40# MESH	35
VPG-100	VACUUM PUMP GAUGE	96
VPS-125	VACUUM PUMP STRAINER 1/8	118
VT-100	VACUUM TRANSDUCER 0-30 HG	516
WFA-750	WATER FILTER BOWL/ASSEMBLY 3/4 (CLEAR)	130
WFB-1	WATER FILTER BOWL/ASSEMBLY 1 (BLUE)	279
WFE-100	WATER FILTER ELEMENT 1 PKG OF 4	348
WFE-750	WATER FILTER ELEMENT 3/4 PKG OF 4	174
WFOR-100	WATER FILTER O-RING 1	26
WFOR-750	WATER FILTER O-RING 3/4	20
WFW-100	WATER FILTER WRENCH 1	105
WFW-750	WATER FILTER WRENCH 3/4	58
WIN-25-100	WATER INJECTION NOZZLE .25 GPM	119
WIN-75-100	WATER INJECTION NOZZLE .75 GPM	119
WMV-100	WATER BYPASS SOLENOID VALVE 1	1,066
WMV-750	WATER BYPASS SOLEN. VALVE 3/4	680
WMVC-750GC	WATER BYPASS SOLEN. VALVE COIL	151
WRC-100	WATER RECYCLER ASSEMBLY	150
WRK-100	WATER RECYCLER KIT	459



Manufacturers of Dental Vacuum
and Air Systems

2657 N. ARGYLE AVE. – FRESNO, CA 93727
(559) 291-1650 (800) 428-7139 FAX (559) 348-9677

WARRANTY CARD

Thank you for purchasing a Tech West Compressor. Our equipment is of the highest standard and carries a substantial warranty. This warranty is valid only if you return this card within 90 days of installation. The warranty period begins on the date of installation. Once again, thank you for purchasing a Tech West compressor. The following are the warranty periods on Tech West equipment.

Oilless Compressor: 5 years OR 3500 hours on motor only
2 years on all other components

Date Installed: _____

Purchased By: Name _____

Address _____

City, State, Zip _____

Phone _____ Fax _____

Purchased From: Name _____

Address _____

City, State, Zip _____

Phone _____ Fax _____

Installed By: Name _____

Address _____

City, State, Zip _____

Phone _____ Fax _____

Product Description _____

Model # _____

Serial # _____



Manufacturers of Dental Vacuum
and Air Systems

2657 N. ARGYLE AVE. – FRESNO, CA 93727
(559) 291-1650 (800) 428-7139 FAX (559) 348-9677

WARRANTY CARD

Thank you for purchasing a Tech West Pump. Our equipment is of the highest standard and carries a substantial warranty. This warranty is valid only if you return this card within 90 days of installation. The warranty period begins on the date of installation. Once again, thank you for purchasing a Tech West vacuum. The following are the warranty periods on Tech West equipment.

Goldenvac: 10 years on stainless steel parts
5 years on motor shaft
3 years on all other components

EcoVac: 5 years OR 5000 hours

Date Installed: _____

Purchased By: Name _____

Address _____

City, State, Zip _____

Phone _____ Fax _____

Purchased From: Name _____

Address _____

City, State, Zip _____

Phone _____ Fax _____

Installed By: Name _____

Address _____

City, State, Zip _____

Phone _____ Fax _____

Product Description _____

Model # _____

Serial # _____



TECHWEST INC

Manufacturers of Dental Vacuum
and Air Systems

2657 N. Argyle Ave. • Fresno, CA 93727
(559) 291-1650 • (800) 428-7139
FAX (559) 348-9677
www.tech-west.com

Effective 3/25